

PRATT & WHITNEY CANADA
MAINTENANCE MANUAL
MANUAL PART NO. 3013242

LIST OF EFFECTIVE PAGES

<u>CHAPTER SECTION</u>	<u>PAGE</u>	<u>DATE</u>	<u>CHAPTER SECTION</u>	<u>PAGE</u>	<u>DATE</u>
LEP	1	Jun 16/2006	6	6	Dec 02/2005
	2 blank	Jun 16/2006	7	7	Dec 02/2005
			8	8	Dec 02/2005
Contents	1	Jun 16/2006	9	9	Dec 02/2005
	2 blank	Jun 16/2006	10	10	Dec 02/2005
			11	11	Dec 02/2005
Introduction	1	Aug 27/2004	12	12	Dec 02/2005
	2	Aug 27/2004	13	13	Dec 02/2005
	3	Aug 27/2004	14	14	Dec 02/2005
	4	Aug 27/2004	15	15	Dec 02/2005
	5	Aug 27/2004	16	16	Dec 02/2005
	6	Aug 27/2004	17	17	Dec 02/2005
Special Tools Fixtures and Equipment	1	Apr 02/2004	18	18	Dec 02/2005
	2	Jun 16/2006	19	19	Dec 02/2005
	3	Jun 16/2006	20	20	Dec 02/2005
	4	Jun 16/2006	21	21	Dec 02/2005
	4 A	Jun 16/2006	22	22	Dec 02/2005
	4 B blank	Jun 10/2005	23	23	Dec 02/2005
	5	Apr 02/2004	24	24	Dec 02/2005
	6	Apr 02/2004	25	25	Dec 02/2005
	7	Apr 02/2004	26	26	Dec 02/2005
	8	Apr 02/2004	27	27	Dec 02/2005
	9	Jun 16/2006	28	28	Dec 02/2005
	10	Jun 16/2006	29	29	Dec 02/2005
	10 A	Jun 16/2006	30	30	Dec 02/2005
	10 B blank	Jun 10/2005	31	31	Jun 16/2006
	11	Jun 10/2005	32	32	Dec 02/2005
	12	Jun 10/2005	33	33	Dec 02/2005
12 A	Jun 10/2005	34	34	Dec 02/2005	
12 B blank	Aug 27/2004	35	35	Dec 02/2005	
13	Apr 02/2004	36	36	Dec 02/2005	
14	Apr 02/2004	37	37	Dec 02/2005	
15	Apr 02/2004	38	38	Dec 02/2005	
16	Dec 02/2005	39	39	Dec 02/2005	
Consumable Materials	1	Dec 02/2005	40	40	Dec 02/2005
	2	Dec 02/2005	41	41	Dec 02/2005
	3	Jun 16/2006	42 blank	42 blank	Dec 02/2005
	4	Dec 02/2005			
	5	Dec 02/2005			

PRATT & WHITNEY CANADA
MAINTENANCE MANUAL
MANUAL PART NO. 3013242

<u>SUBJECT</u>	<u>TABLE OF CONTENTS</u>	<u>PAGE</u>
INTRODUCTION		
1. General		1
2. Customer Support		1
3. Accessories Support		2
4. How to Use this Manual		2
A. Chapter/Section/Subject Numbering		2
B. Chapter 72		2
C. Other Chapters		3
5. Engine Part Nomenclature		3
6. Directional References		3
7. Maintenance Concept		3
A. Line Maintenance		3
B. Heavy Maintenance		3
8. Supplementary Publications		3
9. Service Bulletins		3
10. Abbreviations and Symbols		4
SPECIAL TOOLS/FIXTURES AND EQUIPMENT		
1. General		1
2. Special Tools		1
CONSUMABLE MATERIALS		
1. General		1
2. Consumable Materials		1
3. Suppliers and Supplier Services		17

PRATT & WHITNEY CANADA
MAINTENANCE MANUAL
MANUAL PART NO. 3013242

INTRODUCTION

1. General

- A. This maintenance manual contains the recommended procedures for maintaining PT6A-21/-27/-28 engines manufactured by Pratt & Whitney Canada. Personnel involved with engine maintenance should acquaint themselves with the contents of the following introductory paragraphs for full comprehension of the information contained in this manual.
- B. Any discrepancies, problems or suggestions regarding this publication should be forwarded in writing, using the Pratt & Whitney Canada Customer Feedback Sheet (RSVP), to:

Pratt & Whitney Canada Corp.
1000 Marie-Victorin Blvd
Longueuil, Quebec
Canada J4G 1A1

Attention: Manager Publications Dept (01PB4)

Website: www.pwc.ca

E-mail: publications@pwc.ca

- C. Customer Feedback Sheets are enclosed with new manuals and each subsequent revision. Additional forms may be obtained by contacting: The Supervisor, Publications Customer Services, at the above address.
- D. The on-line Customer Feedback Sheet (RSVP form) is also available on the Pratt & Whitney Canada website (www.pwc.ca).
- E. Procedures in this manual may be accomplished with the engine installed or removed from the airframe. This manual will be revised as necessary to incorporate any changes as they arise and also incorporate latest approved procedures and data. This manual is not customized to any particular airframe installation. Configurational variations that may arise as a result of installation or peculiar requirement will be dealt with in the text as they occur.

2. Customer Support

Customer Support representatives maintain contact with operators and service activities and are available for investigation of any specific difficulty or problem. Request for assistance and/or AOG support should be directed to:

Pratt & Whitney Canada Corp.
1000 Marie-Victorin Blvd.
Longueuil, Quebec
Canada J4G 1A1

Attention: Customer Support

Customer Help Desk (24-hour service):

Toll Free - USA and Canada: 1-800-268-8000

Toll Free - International: (International Access Code) + 8000-268-8000

PRATT & WHITNEY CANADA
MAINTENANCE MANUAL
MANUAL PART NO. 3013242

Other: 1-450-647-8000

FAX: 1-450-647-2888

E-mail: customerhelpdesk@pwc.ca

3. Accessories Support

Accessories may be sent for repair or complete overhaul to:

P&WC Accessories Services
333 rue d'Auvergne (Area 2K)
Longueuil, Quebec
Canada J4H 3Y3

4. How to Use this Manual

A. Chapter/Section/Subject Numbering

Subject matter in this manual is separated into specific Chapters, Sections and Subjects in accordance with ATA Specification No. 100. Each chapter is divided into sections and each section is divided into units. These three elements are shown in large bold numbers at the lower right hand corner of each page, where applicable. Chapters are separated by tab dividers.

Chapters contained in this manual are as follows:

AIRWORTHINESS LIMITATIONS	Life Limited Parts
61	Propeller Control
70	Standard Practices
71	Power Plant
72	Engine
73	Fuel and Control Systems
74	Ignition System
75	Air System
76	Engine Controls
77	Engine Indicating System
79	Oil System

B. Chapter 72

The engine chapter is further broken down into sections:

72-01	Power Section
72-10	Reduction Gearbox

NOTE: An engine that has more than one RGB, will use sequential numbers i.e., 72-11-00, 72-12 -00 etc.

72-20	Air Inlet Section
72-30	Compressor Section

PRATT & WHITNEY CANADA
MAINTENANCE MANUAL
MANUAL PART NO. 3013242

72-40	Combustion Section
72-50	Turbine Section
72-60	Accessory Gearbox

C. Other Chapters

Chapter/Section breakdown for the other Chapters is extensive and is shown in the Table of Contents for each Chapter.

5. Engine Part Nomenclature

For engine areas, bearings, stations, and flanges, refer to 72-00-00, Description and Operation, Figures 1 through 4.

6. Directional References

The terms right and left, clockwise and counterclockwise, upper and lower and similar references will apply to the engine as viewed from the rear, with the engine in a horizontal position and the accessory gearbox facing the viewer.

7. Maintenance Concept

The maintenance functions detailed in this manual fall into two categories: Line Maintenance and Heavy Maintenance. Repairs beyond the levels detailed in this manual are not recommended as maintenance functions and should be done by an approved overhaul facility.

A. Line Maintenance

The scope of line maintenance consists of removal and installation of external components and engine accessories plus a hot section inspection (HSI). All procedures in this manual are to be considered line maintenance in the absence of the words “(Heavy Maintenance Only)” appearing with the procedure title in Maintenance Practices.

B. Heavy Maintenance

Heavy maintenance details removal, installation and repair of components or parts normally considered beyond the capabilities of the average line maintenance facility.

8. Supplementary Publications

Personnel concerned with the maintenance of the engines should familiarize themselves with the contents of the Illustrated Parts Catalog (P&WC Manual P/N 3013244) which lists and describes the saleable parts of the engines and illustrates their inter-relationships.

9. Service Bulletins

Service bulletins will be issued as required to provide information or instructions for modifying engines or parts to the latest configuration.

PRATT & WHITNEY CANADA
MAINTENANCE MANUAL
MANUAL PART NO. 3013242

10. Abbreviations and Symbols

The following is a list of abbreviations and symbols used throughout this manual:

AGB	Accessory Gearbox
AMS	Aerospace Material Specification
Assy	Assembly
ATA	Air Transport Association
beta	Range of propeller blade angle between fine pitch stop and maximum reverse pitch setting
BRG	Bearing
CCW	Counterclockwise
CG	Center of Gravity
CSU	Constant Speed Unit
CT	Compressor Turbine
CW	Clockwise
°C	Degrees Celsius (Centigrade)
°F	degrees Fahrenheit
°R	degrees Rankin
°K	degrees Kelvin
del	delta (P observed/P Standard Day)
del P	Engine Torquemeter Pressure, in. Hg.
del T5	T5 Temperature Trim Value
DELRTH	Delta Root Theta
Dia.	Diameter
Dim	Dimension
eshp	equivalent shaft horse power
FCU	Fuel Control Unit
FI	Flight Idle
FIR	Full Indicator Reading
FOD	Foreign Object Damage
FPI	Fluorescent Penetrant Inspection
FWD (Fwd)	Forward
G	Gravitational Constant
GGM	Gas Generator Module
GI	Ground Idle
Hg	Mercury
HP	High Pressure
hr	hour
HSI	Hot Section Inspection
ID	Inside Diameter
Imp	Imperial
in.	inch

PRATT & WHITNEY CANADA
MAINTENANCE MANUAL
MANUAL PART NO. 3013242

in.Hg.	Inches of Mercury
IPC	Illustrated Parts Catalog
ITT (T5)	Interturbine Temperature
kg	kilogram
lb.	pound
lb.in.	pound inch
LH	Left-hand
LP	Low Pressure
Max.	Maximum
min	minute
Min.	Minimum
mm	millimeter
NA	Not Applicable
Nf (NF)	Power Turbine Speed (rpm or %)
Ng (NG)	Gas Generator Speed (rpm or %)
No.	Number
Np	Propeller Speed (rpm or %)
OD	Outside Diameter
Pam	Ambient Barometric Pressure
Para.	Paragraph
PD	Pitch Diameter
P/N	Part Number
PP	Plenum Pressure
pph	pounds per hour
Psgb	Reduction Gearbox Static Pressure
psi	pounds per square inch
psig	pounds per square inch gage
PSM	Power Section Module
PT	Power Turbine
PTO	Power Take Off
P&WC	Pratt & Whitney Canada Corp.
PWC	Special Tool Prefix Letters - Engine
Px	Control Pressure (Bleed Valve)
Py	Governor Servo Pressure
Po	Bypass Pressure
P1	Unmetered Fuel Pressure or Intake Pressure
P2	Metered Fuel Pressure
P3	Compressor Discharge Air Pressure
(REF.)	reference
RGB	Reduction Gearbox (Propeller)
RH	Right-hand
RTH	Root Theta

PRATT & WHITNEY CANADA
MAINTENANCE MANUAL
MANUAL PART NO. 3013242

rpm	revolutions per minute
SB	Service Bulletin
SCFM	Standard Cubic Feet per Minute
SED	Small Exit Duct
sfc	specific fuel consumption (lb/shp/hr)
SG	Specific Gravity
shp	shaft horse power
SOI	Specific Operating Instructions
SPOP	Service Process Operation Procedure
T	Temperature
tam	Ambient Air Temperature
TBA	To be advised
TBO	Time Between Overhaul
theta	T observed/T standard day
TIG	Tungsten Inert Gas (Welding method)
T1	Engine Inlet Temperature
T5 (ITT)	Inter-turbine Temperature
UOS	Unless Otherwise Specified
USA	United States of America
Wf	Fuel Flow (lb/hr)

**PRATT & WHITNEY CANADA
MAINTENANCE MANUAL
MANUAL PART NO. 3013242**

SPECIAL TOOLS/FIXTURES AND EQUIPMENT

1. General

This section gives data about the special tools and the fixtures and equipment required to maintain the engine.

2. Special Tools

Special tools, required to maintain the engine are listed in Table 1.

Depending on the geographical location of the operator, requests for the purchase of special tools, should be sent to:

USA:

Kell-Strom Tool Company Inc.
214 Church Street, P.O. Box 240
Wethersfield, CT 06109
USA

TEL: 860-529-6851 or
1-800-851-6851 (USA and Canada)
FAX: 860-257-9694

Website: <http://www.kell-strom.com>

E-mail: lpriest@kell-strom.com

or

Pratt & Whitney, Tool Support Services
411 Silver Lane, Mail Stop 129-20
East Hartford, CT 06118
USA

TEL: 860-565-0140 or
1-800-PWA-TOOL (USA and Canada)
FAX: 860-610-2670

E-mail: lemirejw@pweh.com

CANADA and all other locations:

Pratt & Whitney Canada, Tooling Solutions
333 rue d'Auvergne (02AN1)
Longueuil, Quebec
Canada J4H 3Y3

TEL: 450-442-5400 or
1-800-3-115-5122 (Canada, USA and International)
FAX: 450-442-5420

Website: <http://www.pwctoolingsolutions.com>

E-mail: henri.hudon@pwc.ca or
frank.caruso@pwc.ca

PRATT & WHITNEY CANADA
MAINTENANCE MANUAL
MANUAL PART NO. 3013242

or

Rasakti Inc.
 148 Sylvestre
 St-Germain-de-Grantham, Quebec
 Canada J0C 1K0
 TEL: 819-395-1111 or (24 hour service number)
 1-888-RASAKTI (727-2584) (Canada & USA)
 FAX: 819-395-1100
 Website: <http://www.rasakti.com>
 E-mail: l.poirier@rasakti.com

TABLE 1, Special Tools

Part No.	Name	CH/SE/SU	Maintenance Level	
			Line	Heavy
PWC30037	Sling - Replaced by PWC70099	72-00-00	X	X
PWC30046-52	Puller (Pre-SB1386)	72-60-00	X	X
PWC30046-54	Puller (Post-SB1386)	72-60-00	X	X
PWC30046-57	Puller	72-10-00	X	X
		72-60-00	X	X
PWC30051-01	Base	72-60-00		X
PWC30051-02	Drift	72-60-00		X
PWC30052	Puller	72-60-00		X
PWC30054	Drift (Pre-SB1386)	72-60-00		X
PWC30075	Drift	72-10-00	X	X
		72-60-00	X	X
PWC30077	Puller	72-00-00	X	X
PWC30114-08	Wrench	77-20-01	X	X
PWC30114-09	Wrench (Pre-SB1232)	61-20-00	X	X
PWC30114-16	Wrench (Post-SB1232)	61-20-00	X	X
PWC30128-04	Puller	72-60-00		X
PWC30269	Ring	72-00-00	X	X
PWC30271-100	Spreader - Replaced by PWC31771	72-30-04	X	X
PWC30274	Base	72-60-00		X
PWC30328	Puller	79-20-02	X	X
PWC30331	Wrench	72-50-02		X

PRATT & WHITNEY CANADA
MAINTENANCE MANUAL
MANUAL PART NO. 3013242

TABLE 1, Special Tools (Cont'd)

Part No.	Name	CH/SE/SU	Maintenance Level	
			Line	Heavy
PWC30332	Wrench	72-50-04		X
PWC30335	Spreader	72-50-02	X	X
		72-50-04		X
PWC30336	Protector	72-50-02		X
PWC30338	Sling - Replaced by PWC70652 and PWC70653	72-00-00	X	X
PWC30373	Puller/Pusher	72-60-00		X
PWC30403	Puller	72-50-02	X	X
		72-50-04		X
PWC30405	Fixture	73-10-05	X	X
PWC30415	Compressor	72-60-00	X	X
PWC30416	Puller	73-10-05	X	X
PWC30425	Crimping Pliers	77-20-01		X
PWC30458	Squeezer	72-50-02	X	X
		72-50-04		X
PWC30478	Spacer	72-50-01	X	X
PWC30499-50	Gage	72-60-00	X	X
PWC30506	Rig	73-10-05	X	X
PWC30518	Puller	79-20-04	X	X
PWC30530	Plug	73-10-05	X	X
PWC30556	Puller	79-20-02	X	X
PWC30675	Drift (Post-SB1386)	72-60-00	X	X
PWC30712	Adapter	72-00-00	X	X
PWC31771	Spreader	72-30-04	X	X
PWC30854	Drift	72-60-00		X
PWC30863	Puller	72-50-01		X
PWC32072	Puller	72-10-00		X
PWC32073	Sling - Replaced by PWC34073	72-00-00	X	X
PWC32179	Base Assembly - Replaces PWC30322	72-00-00		X
PWC32209	Adapter	72-50-01		X

PRATT & WHITNEY CANADA
MAINTENANCE MANUAL
MANUAL PART NO. 3013242

TABLE 1, Special Tools (Cont'd)

Part No.	Name	CH/SE/SU	Maintenance Level	
			Line	Heavy
PWC32212	Alignment Pins	72-50-03	X	X
PWC32271	Wash Tube	71-00-00	X	X
PWC32275	Split Plate	72-60-00	X	X
PWC32366	Pusher, Tubes	73-10-05	X	X
PWC32380	Radius Gage	72-50-01		X
PWC32396	Jackscrew - 3 required	72-60-00		X
PWC32420	Sling - Replaced by PWC51861	72-00-00	X	X
PWC32483	Cutter	72-30-00		X
PWC32484	Gage	72-30-00		X
PWC32528	Wheel, Grinding	72-50-01		X
PWC32677-100	Washcart, Compressor	71-00-00	X	
PWC32811	Fixture	73-10-05	X	X
PWC34073	Sling - Replaced by PWC70099	72-00-00	X	X
PWC34300	Engine Stand - Replaced by PWC51140	72-00-00	X	X
PWC34910-101	Borescope Assembly	72-00-00	X	
PWC34910-200	Guide Tube	72-00-00	X	
PWC34913	Holding Fixture	72-00-00	X	
PWC34941	Wrench	72-00-00	X	X
PWC37088-001	Drift	72-60-00	X	X
PWC37088-002	Drift	72-60-00	X	X
PWC37088-003	Drift	72-60-00	X	X
PWC37917	Dresser	72-50-01		X
PWC37918	Grinder	72-50-01		X
PWC50057	Drill	72-50-02		X
PWC50060	Injector	72-50-02		X
PWC50502	Compressor	72-60-00		X
PWC51140	Engine Stand	72-00-00	X	X
PWC51861	Sling - Engine	72-00-00	X	X
PWC70099	Sling (PS - without prop)	72-00-00	X	X

PRATT & WHITNEY CANADA
MAINTENANCE MANUAL
MANUAL PART NO. 3013242

TABLE 1, Special Tools (Cont'd)

Part No.	Name	CH/SE/SU	Maintenance Level	
			Line	Heavy
PWC70652	Sling (PS - with prop)	72-00-00		X
TABLE 1, Special Tools (Cont'd)				
PWC70653	Sling Adapter (used with PWC70652)	72-00-00		X

PRATT & WHITNEY CANADA
MAINTENANCE MANUAL
MANUAL PART NO. 3013242

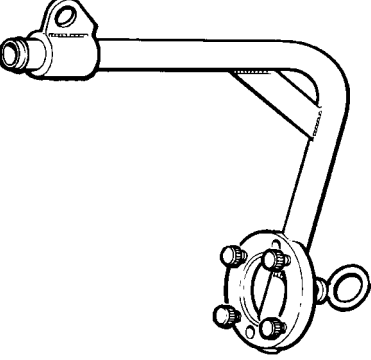
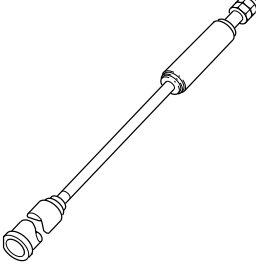
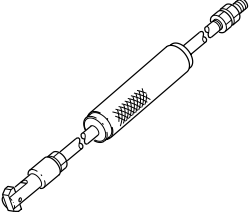
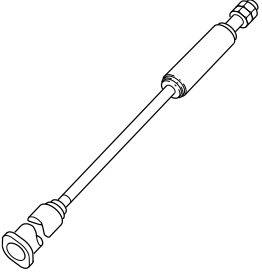
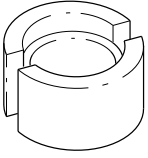
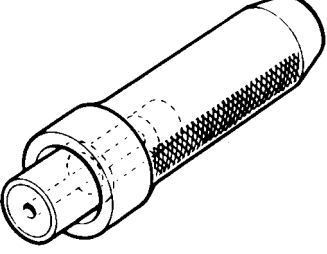
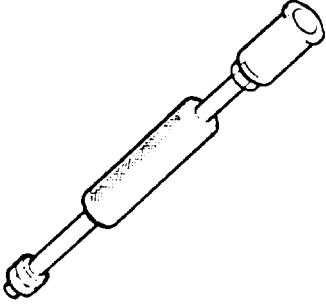
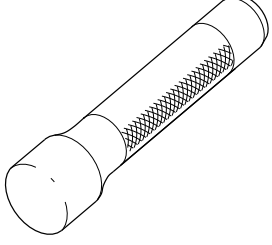
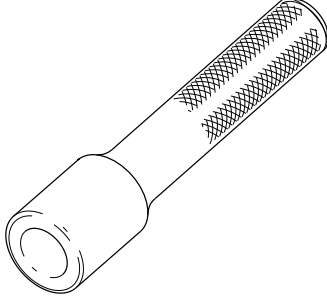
<p>PWC30037</p> 	<p>PWC30046-57</p> 	<p>PWC30052</p> 
<p>PWC30046-52</p> 	<p>PWC30051-01</p> 	<p>PWC30054</p> 
<p>PWC30046-54</p> 	<p>PWC30051-02</p> 	<p>PWC30075</p> 

Special Tool Illustrations

PRATT & WHITNEY CANADA
MAINTENANCE MANUAL
MANUAL PART NO. 3013242

PWC30077

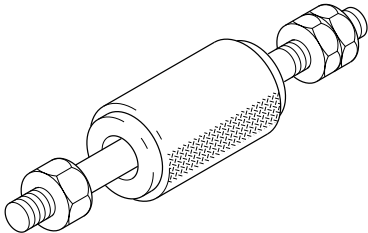

PWC30114-16

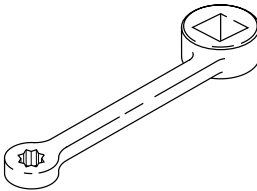

PWC30271-100

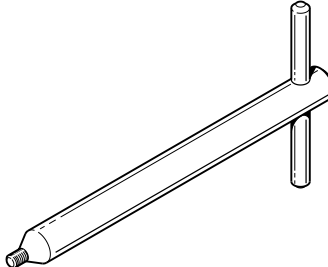

PWC30114-08

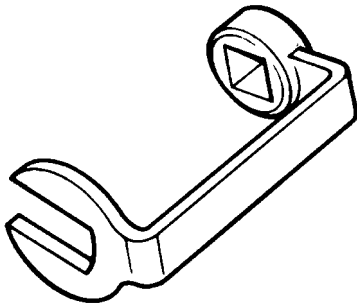

PWC30128-04

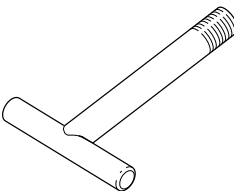

PWC30274

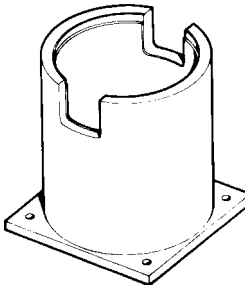

PWC30114-09

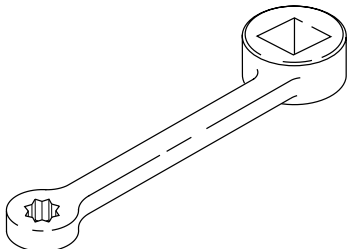

PWC30269

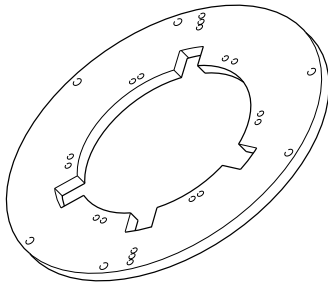

PWC30328

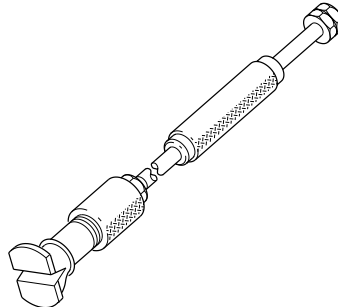

Special Tool Illustrations

PRATT & WHITNEY CANADA
MAINTENANCE MANUAL
MANUAL PART NO. 3013242

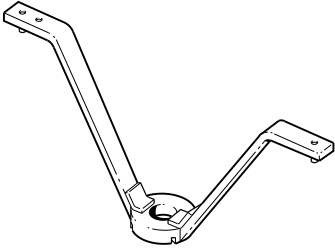
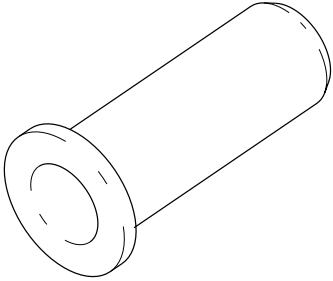
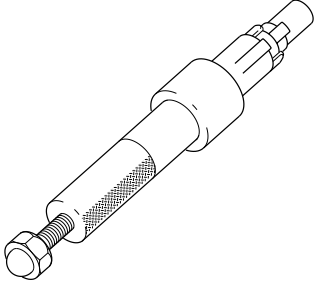
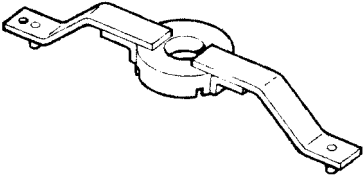
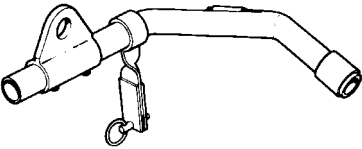
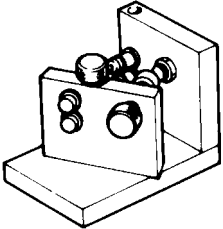
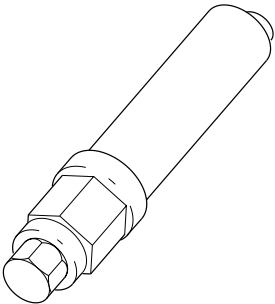
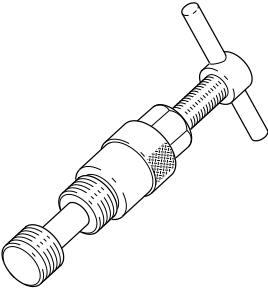
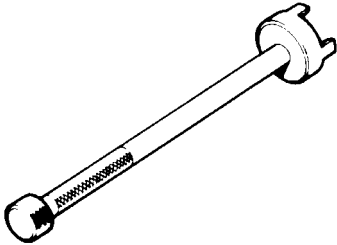
<p>PWC30331</p> 	<p>PWC30336</p> 	<p>PWC30403</p> 
<p>PWC30332</p> 	<p>PWC30338</p> 	<p>PWC30405</p> 
<p>PWC30335</p> 	<p>PWC30373</p> 	<p>PWC30415</p> 

Special Tool Illustrations

**PRATT & WHITNEY CANADA
MAINTENANCE MANUAL
MANUAL PART NO. 3013242**

PWC30416

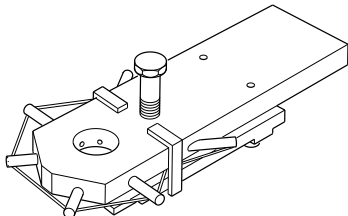

PWC30478

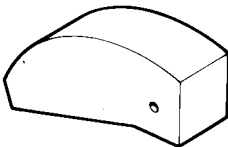

PWC30518

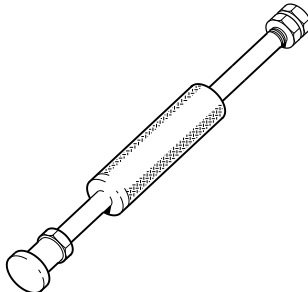

PWC30425

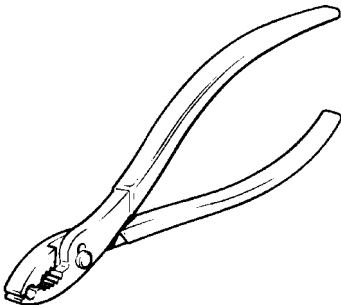

PWC30499-50

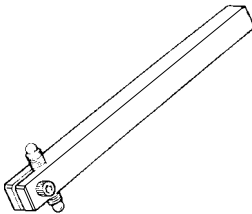

PWC30530

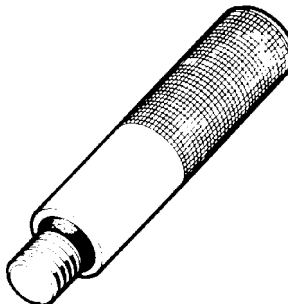

PWC30458

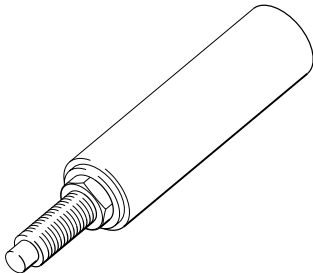

PWC30506

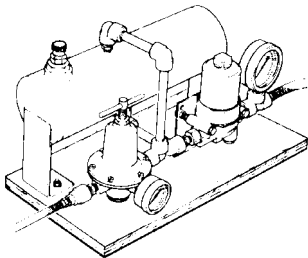

PWC30556

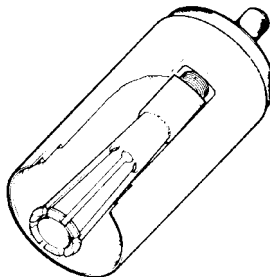

Special Tool Illustrations

PRATT & WHITNEY CANADA
MAINTENANCE MANUAL
MANUAL PART NO. 3013242

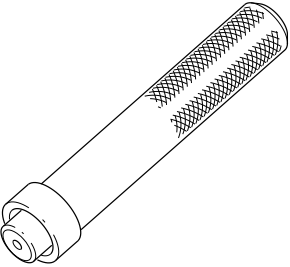
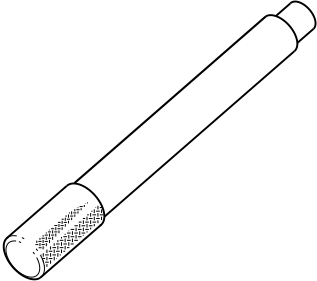
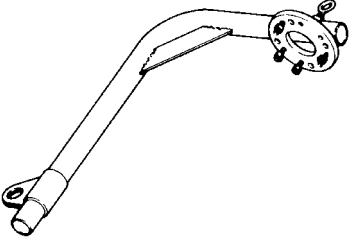
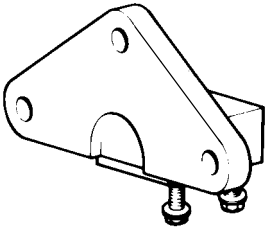
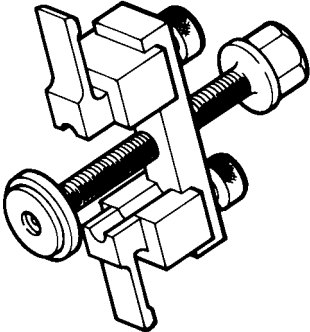
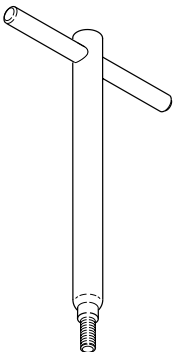
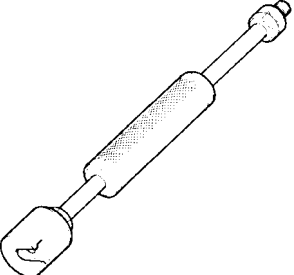
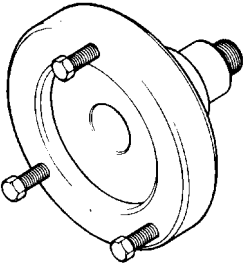
<p>PWC30675</p> 	<p>PWC30854</p> 	<p>PWC32073</p> 
<p>PWC30712</p> 	<p>PWC30863</p> 	<p>PWC32179</p> <p>TOOL NOT ILLUSTRATED</p>
<p>PWC31771</p> 	<p>PWC32072</p> 	<p>PWC32209</p> 

Special Tool Illustrations

PRATT & WHITNEY CANADA
MAINTENANCE MANUAL
MANUAL PART NO. 3013242

PWC32212

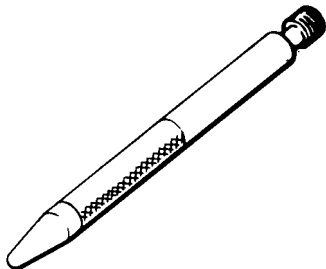

PWC32366

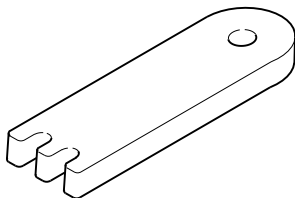

PWC32420

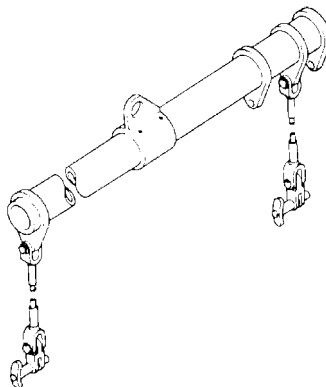

PWC32271

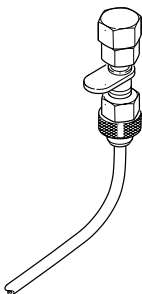

PWC32380

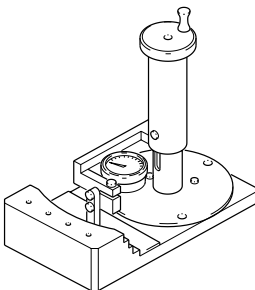

PWC32483

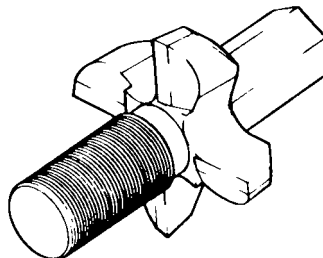

PWC32275

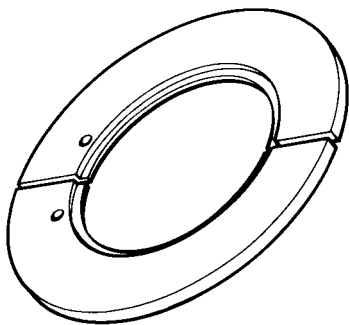

PWC32396

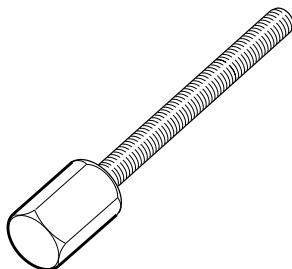

PWC32484

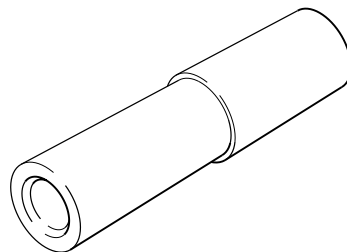

Special Tool Illustrations

**PRATT & WHITNEY CANADA
MAINTENANCE MANUAL
MANUAL PART NO. 3013242**

PWC32528

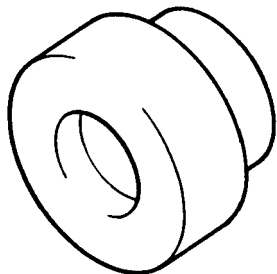

PWC32677-100

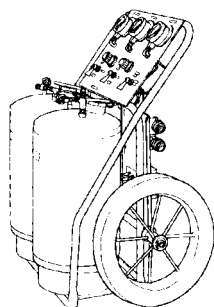

Special Tool Illustrations

PRATT & WHITNEY CANADA
MAINTENANCE MANUAL
MANUAL PART NO. 3013242

PWC32811

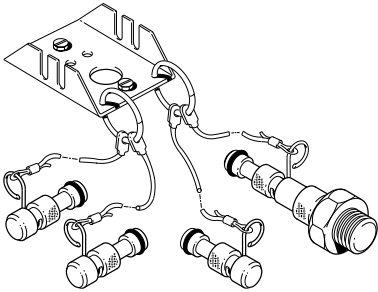

PWC34910-101

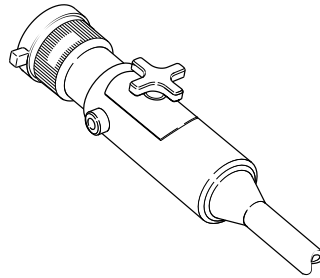

PWC34941

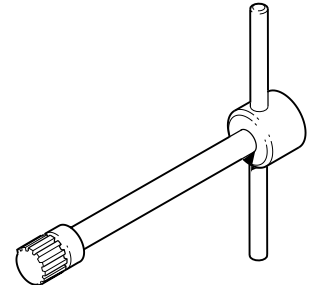

PWC34073

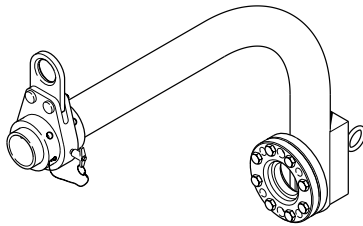

PWC34910-200

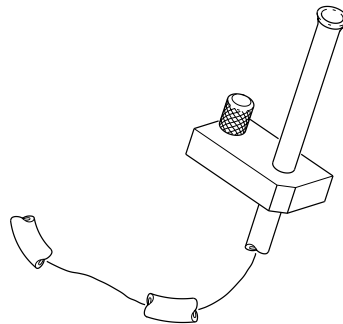

PWC37088-001

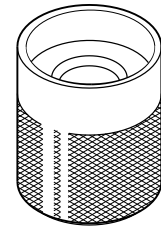

PWC34300

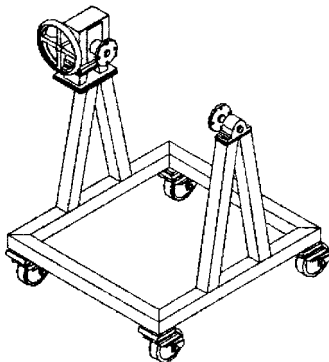

PWC34913

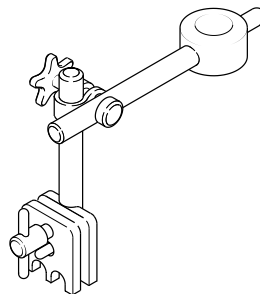

PWC37088-002

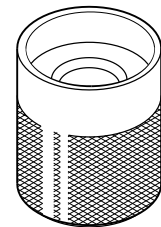

Special Tool Illustrations

**PRATT & WHITNEY CANADA
MAINTENANCE MANUAL
MANUAL PART NO. 3013242**

PWC37088-003

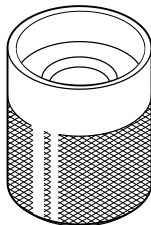

PWC50057

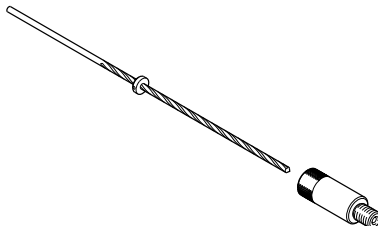

PWC51140

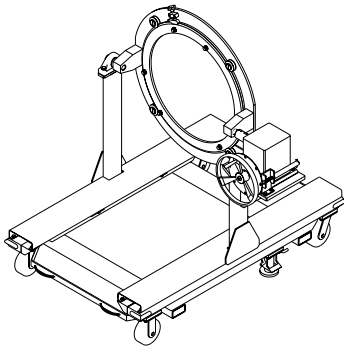

PWC37917

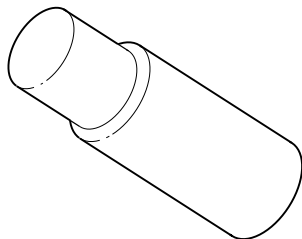

PWC50060

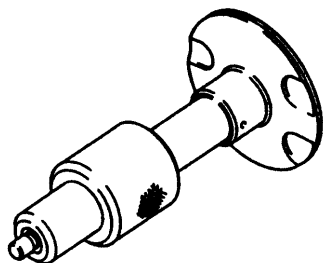

PWC51861

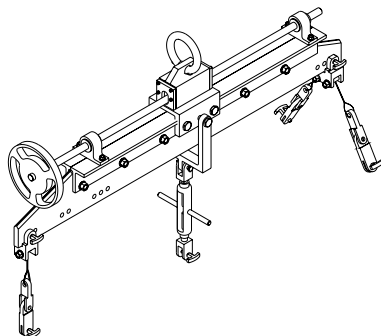

PWC37918

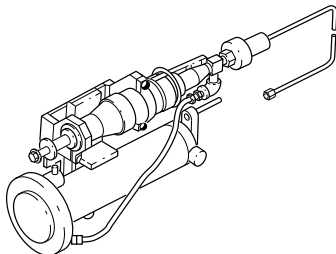

PWC50502

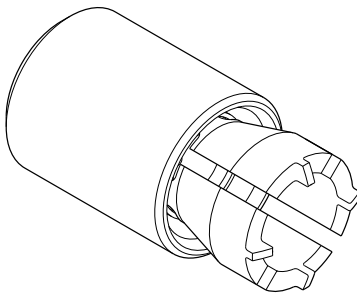

PWC70099

**TOOL
NOT
ILLUSTRATED**

Special Tool Illustrations

**PRATT & WHITNEY CANADA
MAINTENANCE MANUAL
MANUAL PART NO. 3013242**

PWC70652

**TOOL
NOT
ILLUSTRATED**

PWC70653

**TOOL
NOT
ILLUSTRATED**

Special Tool Illustrations

PRATT & WHITNEY CANADA
MAINTENANCE MANUAL
MANUAL PART NO. 3013242

When ordering special tools, include the prefix 'PWC' as a component of the tool part number, e.g. PWC 30338, Sling.

To allow for local manufacture of basic line maintenance tools, the following fully dimensioned tool drawings are presented as a P&WC CD Publication, P/N 3054921, available free of charge to subscribers of P&WC Maintenance Manuals.

- PWC30046 Puller
- PWC30075 Puller
- PWC30077 Puller
- PWC30114 Wrench
- PWC30128 Puller
- PWC30415 Compressor
- PWC30518 Puller
- PWC30675 Drift

For information and ordering, contact:

Pratt & Whitney Canada Corp.
 1000 Marie-Victorin Blvd.
 Longueuil, Quebec
 Canada J4G 1A1

Attention: Manager Publications 01PB4

3. Special Equipment

Special equipment listed in Table 2 is considered as any equipment, material, fixture which is not PWC derived and is not considered a consumable material.

TABLE 2, Special Equipment

Name	Part No.	Supplier
Turbine Temperature Indicating System Test Set (Ref. 77-20-01, 77-20-00)	TT1000A	Barfield Instrument Corp. 4101 NW 29th St. P.O. Box 527705 Miami, FL 33152-7705 USA Tel.: (305) 871-3900
Pressure Tester (Ref. 73-10-05)	2311F	Barfield Instrument Corp.
A.C./D.C. Arc Welding Machine; 150 amp minimum capacity with close control in 15 to 75 amp. range. (High frequency control for ease of arc starting is desirable) (Ref. 70-00-00).	P and H Model DA-300-HF-GW or equivalent	Local Purchase

PRATT & WHITNEY CANADA
MAINTENANCE MANUAL
MANUAL PART NO. 3013242

TABLE 2, Special Equipment (Cont'd)

Name	Part No.	Supplier
Air Pressure Regulator: 100 psi input, 0 to 100 psi output. (Ref. 75-30-00)		Local Purchase
Shutoff Valve (Air Line) (Ref. 71-00-00, 75-30-00)		Local Purchase
Pressure Gage; 0 to 75 psi, accuracy ±5 percent (Ref. 71-00-00, 75-30-00)		Local Purchase
Argon Regulator (Ref. 70-00-00)	Airco 8407 or equivalent	Local Purchase
Flowmeter Block Assemblies, 2 required (Ref. 70-00-00)	Airco 830-1327 or equivalent	Local Purchase
Shielded Arc Torch; with provision for supply of inert gas (argon) and cooling water. (Ref. 70-00-00)	Linde Model HW-10 or Airco H35B or equivalent	Local Purchase
Shielded Arc Torch; with provision for supply of inert gas (argon) and cooling water. (Ref. 70-00-00)	Linde Model HW-9 or Airco H20A or equivalent	Local Purchase
Ground Cable; 25 feet approx.	Size 0	Local Purchase
Arc Cable, metallic; 25 feet approx.	Size 0	Local Purchase
Argon Hose; 25 feet approx.		Local Purchase
Two Stainless Steel Tanks; 6 gallon capacity and capable of withstanding 50 psi (Ref. 71-00-00).		Local Purchase
Two Stainless Steel Tanks; 5 gallon capacity and capable of withstanding 50 psi (Ref. 71-00-00).		Local Purchase
Tubing, Stainless Steel $\frac{5}{16}$ inch ID, length as required (Ref. 71-00-00).		Local Purchase

PRATT & WHITNEY CANADA
MAINTENANCE MANUAL
MANUAL PART NO. 3013242

TABLE 2, Special Equipment (Cont'd)

Name	Part No.	Supplier
Restrictor; 0.062 inch. (Ref. 71-00-00)		Local Purchase
Nitrogen or Clean Air Pressure Supply regulated to 50 psig		Local Purchase
Pressure Gage Adapter threaded to suit pressure gage (item No. 6) and bleed valve cover (0.250-28 UNJF-3B)		Local Manufacture/ Purchase
Test Rig Adapters, threaded to accept tubing for pressure regulator (item No. 4) shut-off valve (item No. 5) and bleed valve cover (0.250-28-UNJF-3B)		Local Manufacture/ Purchase
Fuel Nozzle Flushing Fixture (Ref. 73-10-05)		Local Manufacture
Stainless Steel Container or Tray, Perforated (to suit Electrosonic Cleaner) (Ref. 73-10-05)		Local Manufacture
Ultrasonic Cleaner, Esterline Angus (Ref. 73-10-05)	Model T-12, or similar (See NOTE) (Ref. 73-10-05)	Esterline Corp. P.O. Box 2400 Indianapolis, IN 26224, USA or Instro Test Ltd. 1024 Notre Dame Lachine, Quebec, Canada
Electrosonic Cleaner (Ref. 79-20-02)	Model KS518	Kel-Strom Tool Co. 214 Church St. Wethersfield, CT 06109 USA or
	SONAC S-2	Aerosupport Ltd. Box 114, Station A Longueuil, Quebec Canada

NOTE : In the event of non-availability of ultrasonic cleaning equipment, operators should ship fuel nozzles requiring cleaning and testing to an approved overhaul facility, or to a maintenance base having suitable equipment.

**PRATT & WHITNEY CANADA
MAINTENANCE MANUAL
MANUAL PART NO. 3013242**

TABLE 2, Special Equipment (Cont'd)

Name	Part No.	Supplier
Shut-off Valve (Fluid Line) (Ref. 72-00-00)		Local Purchase
Locking Tool (Keensert) (Ref. 72-30-01)	TD1032L	Tridair Industries 3000 West Lomita Blvd. Torrance, CA 90505, USA or Interfast Inc. 21 Constellation Court Rexdale, Ontario Canada M9W 1K4
Oil Filter Element Rinsing and Debris Apparatus Kit (Ref. 79-20-02)	AVL-OFRA	Aviation Laboratories 5401 Mitchelldale #B6 Houston, TX 77092 USA Tel.: 713-864-6677 Tel.: 800-256-6876 Fax: 713-864-6990

PRATT & WHITNEY CANADA
MAINTENANCE MANUAL
MANUAL PART NO. 3013242

CONSUMABLE MATERIALS

1. General

This section gives data about the consumable materials listed in this manual.

2. Consumable Materials

The term "Consumable Material" shall be defined as an expendable substance which is not separately obtained from Pratt & Whitney Canada and which may be applied to the engine or its parts during maintenance.

In many instances, products such as cleaning materials, are mentioned by their trade names to assist the operator in identifying the product types. These names are representative examples only and their inclusion does not necessarily exclude the use of other equivalent products.

Specification numbers applying to consumable materials are basic numbers and shall be interpreted to include all revisions and amendments thereto.

Material Safety Data Sheets (MSDS) containing information about Trade Name, Safety Hazards, Health Hazards, Reactivity, Spill or Leak Procedures, Special Protection Information, Special Precautions, and Transportation and Labelling are available from the manufacturer of the products. Read the data sheets prior to using the consumable materials.

A supplier code with a (m) after the code is the manufacturer of the material and a supplier code with a (s) after the code is a supplier/distributor of the material.

Table 1 describes consumable materials used in the maintenance of the engine.

TABLE 1, Consumable Materials

Item	Nomenclature/Specification	Supplier Code
PWC01-001	Fuel, Engine (Ref. Approved Service Bulletins)	A0001
PWC03-001	Oil, Engine Lubricating (Ref. Approved Service Bulletins)	A0001
PWC03-002	Fluid, Calibrating US MIL-PRF-7024 Type II PMC 9041	A0015
PWC04-001	Grease, Synthetic General Purpose MIL-G-23827 QPL-23827-18 NATO G-354 PMC79671	A0001

PRATT & WHITNEY CANADA
MAINTENANCE MANUAL
MANUAL PART NO. 3013242

TABLE 1, Consumable Materials (Cont'd)

Item	Nomenclature/Specification	Supplier Code
PWC04-004	Compound, High Temperature (Bentonite-type) Plastilube No. 3	1V074
PWC04-005	Grease Extreme Pressure Lubriplate 130A PMC79919	73219, A0032, A0033, A0034, A0035
PWC05-002	Dye, Layout Micro Supreme No. 142 PMC4062	01058
PWC05-003	Cloth, Abrasive Silicone Carbide	A0001(s)
PWC05-005A	Emulsifier Witconate HC-59B	36382, 85665
PWC05-007	Fluid, Leak Check Leak Tec 372 PMC9569	03530
PWC05-009	Ammonium Bifluoride Ref. Crystalline	A0001(s)
PWC05-011	Ammonium Nitrate Powder Form 1.725 Specific Gravity US MIL-A-175 PMC1517	A0001(s)
PWC05-014	Cloth, Abrasive Ref. Scotch Brite	A0001(s), 28112
PWC05-018	Pencil, Metal Marking Hard Ref. Design Spectracolor Silver 1428 PMC4094	22980(m)
PWC05-18A	Pencil, Metal Marking Hard Ref. Stock No. 02460 for Prismacolor Verithin 753 or Stock No. 03375 for Prismacolor Thick Lead 949 PMC 4059-7 (Silver)	22980(m)

PRATT & WHITNEY CANADA
MAINTENANCE MANUAL
MANUAL PART NO. 3013242

TABLE 1, Consumable Materials (Cont'd)

Item	Nomenclature/Specification	Supplier Code
PWC05-18E	Pencil, Metal Marking Hard Ref. Best No. 349 Red PMC4059-6	70362, A0006
PWC05-019	Compound, Lapping Silicon Carbide Clover 2A No. 400 Grit US ANSI B74.10, ANSI B74.12 PMC3013	05972
PWC05-027	Ink, Marking Ref. Carter 21451 Black	S0089
PWC05-031	Flux, Resin Ref. No. 1545 PMC2000	09185(m), 10178(m)
PWC05-037	Enamel, Epoxy Aluminized Ref. Desoto Super -Koropon 529K002 Base + 910K021 Curing Solution PMC1746, PMC1747 PWA569 (CPW269)	A0097(s), S0098(s), ONYS9(m)
PWC05-038	Hydrogen Peroxide Commercial Grade 32.5 to 35% US Fed. A-A-53707 PMC1602	A0001(s), 08338
PWC05-041	Dye, Layout Ref. Dykem Steel Blue PMC74002	98148(m)
PWC05-046A	Marker, Ink Fast Drying, No. 57 400-1 Black, 400-2 Red, 400-7 Purple	S0036

PRATT & WHITNEY CANADA
MAINTENANCE MANUAL
MANUAL PART NO. 3013242

TABLE 1, Consumable Materials (Cont'd)

Item	Nomenclature/Specification	Supplier Code
PWC05-046C	Marker, Ink Ref. Dykem KX425 or DykemKXX122	98148(m)
PWC05-048	Pen, Marking Ref. Brushpen No. 57	S0036
PWC05-048A	Pen, Marking Ref. Felt Wick Pen	A0013, 30133
PWC05-048B	Ref. PWC05-331	
PWC05-049	Material, Masking Ref. Brady Mask PMC74110	A0026
PWC05-050	Nitrogen Technical Grade Ref. Minimum Purity 99% US. BB-N-411 PMC2212	A0001(s), 0BZD7, 09563
PWC05-052	Sheathing, Heat Shrinkable Ref. Silicone Rubber 1 in. (25.4 mm) Dia.	A0001(s), 06090
PWC05-055	Sodium Hydroxide, (Technical Grade) Ref. Open Commercial Grade PMC 1300	A0001(s)
PWC05-058	Solder, Tin-Alloy Ref. 50/50 Mix US.ANSI J-STD-004 ANSI J-STD-005 ANSI J-STD-006	09185(m), 10178(m)
PWC05-061	Cloth, Abrasive Coated Crocus US Fed. A-A-1206,	A0001(s), 44197 (m), 61158(m)
PWC05-063	DELETED	
PWC05-064	Solution, Anodize Touch-Up (for Aluminum Alloys) Ref. Alodine No. 1200S US. AMS 2473 PMC 71600	84063

PRATT & WHITNEY CANADA
MAINTENANCE MANUAL
MANUAL PART NO. 3013242

TABLE 1, Consumable Materials (Cont'd)

Item	Nomenclature/Specification	Supplier Code
PWC05-066	Tape, High Temp. (Glass Cloth) Ref. Permacel No. 212 PMC4273 to 4273-8	A0001(s), 99742(m)
PWC05-070	Tape, Pressure Sensitive Adhesive Filament Reinforced Ref. 3M No. 898 Type II, 2 .0 in. (50.8 mm) Wide US. Fed. PPP-T-97D	A0001(s), A0083, 76381(m)
PWC05-073	Water, Distilled Deionized and Demineralized Ref. Commercial Grade PMC1737, PMC71000	A0001(s)
PWC05-074	Acid, Sulfuric Ref. Commercial or Technical Grade 66 Degrees Baume PMC1003	A0001(s)
PWC05-075B	Grit, Abrasive Aluminum Oxide No. 60 Mesh PMC3052-1	A0001(s), 33333, 44197(m)
PWC05-076	Oil, Penetrating US Fed. A-A-50493	A0001(s), 59595
PWC05-077	Oil, Preservative Ref. Grade 1010 US. MIL-L-6081	2R128
PWC05-089	Lockwire Nickel Alloy (CRES) Ref. MS9226-03 US. AMS5687 0.025 in. (0.64 mm) Dia. (for engine external applications only, PWC05-294 may be substituted).	A0001(s), 8W577(m)
PWC05-101	Cloth, Abrasive Aluminum Oxide or Silicone Carbide US Fed. A-A-1200 No. 320 Grit	A0001(s), 44197(m), 61158(m)

PRATT & WHITNEY CANADA
MAINTENANCE MANUAL
MANUAL PART NO. 3013242

TABLE 1, Consumable Materials (Cont'd)

Item	Nomenclature/Specification	Supplier Code
PWC05-103	Marker, Pencil (Surface Marking) Ref. Phano No. 71 Red	70362
PWC05-105	Tape, Self-Adjusting Insulation Electrical Ref. Silicone Rubber US. MIL-I-46852	A0001(s), 00198(s)
PWC05-110	Lockwire Nickel Alloy or Inconel 600 Ref. MS9226-01 US. AMS5687 0.016 in. (041 mm) Dia.	A0001(s), 8W577(m)
PWC05-118	Insert, Keensert Ref. KN 1032	29372, 39211
PWC05-145	Ref. PWC05-019	
PWC05-147	Electrode 2% Thoriated Tungsten PMC5052-3 Length: 7 in. (177.8 mm) Diameter: 1/16 in. (1.587 mm)	A0001(s), 05838, 28835
PWC05-151	Wire, Filler, Welding (Inconel 625) US AMS5837	A0001(s), OHJT8, 2R602
PWC05-156	Bars, Wire, Forgings Alloy 51410 US AMS5613	A0001(s), 8W577(m)
PWC05-161	Solution, Chrome Pickle Touch-Up 1.5 pints nitric acid (PWC05-195) to 1.5 pints sodium dichromate (PWC05-055) SG of 1.42 Add to 8 pints of water. (PWC05-073)	A0001(s)
PWC05-162	Wetting Agent Chromate Conversion Salts Ref. ARP No. 2 PMC1632	76071, A0001(s)

PRATT & WHITNEY CANADA
MAINTENANCE MANUAL
MANUAL PART NO. 3013242

TABLE 1, Consumable Materials (Cont'd)

Item	Nomenclature/Specification	Supplier Code
PWC05-164	Welding Material Alumel Ref. TYPE K 20 GAGE	A0066
PWC05-165	Crystals Silver Nitrate Ref. Open	A0001(s)
PWC05-166	Solution, Chemical Treatment Ref. MIL-C-5541 Class 1A	A0001(s), 71410
PWC05-167	Grit, Abrasive Ref. Open No. 1200 Mesh	A0001(s)
PWC05-168	Compound, Polishing, Greaseless-Medium Ref. HD-15 Medium PMC3021	75554(m), A0001(s)
PWC05-179	Wire, Filler, Welding Ref. FM69 US. AMS5778	A0001(s), OHJT8, 2R602
PWC05-180	Wire, Filler, Welding Ref. Hastelloy X US AMS5798	A0001(s), OHJT8, 2R602
PWC05-190	Patch, Filter Ref. P/N NY6004700 Millipore 60 Micron Nylon	A0084(s), 08071(m)
PWC05-195	Acid, Nitric Technical Grade US O-N-350 5 to 10% Solution 42% Reagent Grade 45 Degrees Baume PMC1000	A0001(s)
PWC05-196	Acid, Hydrochloric Technical Grade Ref. Muriatic Acid US ASTM E1146 MIL-H-13528 37 % Reagent Grade 20 Degrees Baume PMC1002	A0001(s)

PRATT & WHITNEY CANADA
MAINTENANCE MANUAL
MANUAL PART NO. 3013242

TABLE 1, Consumable Materials (Cont'd)

Item	Nomenclature/Specification	Supplier Code
PWC05-197	Acid, Chromic Flakes or Solution US Fed. O-C-303 CR03-99.5% Min. SO4 -0.20% Max. Commercial Grade PMC1001	A0001(s)
PWC05-215A	Wire, Filler, Welding (Nickel Alloy) US AMS5786 0.035 in. (0.89 mm)	A0001(s), OHJT8, 2R602
PWC05-227	Alloy, Coating Cobalt Cast Rods, Pressed Sintered and Extruded or Powder Ordered	57965, 0CZB2
PWC05-273	Sleeve, Shrink Self-adhesive Ref. Raychem HTAT 48/13	K1010, 06090
PWC05-294	Lockwire or Safetywire Nickel Alloy (CRES) (for engine external applications only, may be used as a substitute for PWC05-089). Ref. AS3214-01 0.020 in. (0.500 mm) Dia.	A0001(s), 1A053(s)
PWC05-329	Temperature Recorder, Single Position (Self Adhesive) Ref. P/N 414-140F-060C 0.56 in. (14 mm) diameter	A0123
PWC05-331	Felt Tip Marker Rapid Drying Temporary Marking Ref. PMC 4050	See NOTE
NOTE: For trade names and manufacturers, refer to the SPM. Remove the marking ink from the part before heat treatment process and assembly.		
PWC05-353	Welding Material Chromel Ref. TYPE N 20 GAGE	A0066

PRATT & WHITNEY CANADA
MAINTENANCE MANUAL
MANUAL PART NO. 3013242

TABLE 1, Consumable Materials (Cont'd)

Item	Nomenclature/Specification	Supplier Code
PWC06-001	Compound, Lubricating Aerosol Spray Application Ref. DC321 Moly Spray (CPW307)	71984(m)
PWC06-002	Use PWC03-001	
PWC06-003	Compound, Antigalling Corrosion Prevention Ref. Fel-Pro C-652 PWA 559, PMC79911	73165(m)
PWC06-004	Compound, Antiseize (Molybdenum Disulfide) Ref. Dow Corning G-N Metal Assembly Paste US. MIL-M-7866 PWA587, PMC9549 (CPW262)	71984(m), A0018(s)
PWC06-005D	Lubricant, Fluorocarbon PTFE Release Agent Ref. MS-122DF Aerosol Spray	18598(m), 1DD67(m), 1E473(m), A0103(s)
PWC06-007	Lubricant, Dry Film Ref. Moly Dry Film Lub PMC79910 (CPW323)	73165(m)
PWC06-009	Compound, Antiseize Ref. NEVER-SEEZ Pure Nickel Special PWA36053 or PWA36053-1 PMC79966, (CPW553)	5W425(m), 75437
PWC06-012	Grease, Bearing (Long Life) Ref. FS-1292	A0001(s), 71984(m), D8367(m)
PWC06-023	Compound, Antiseize Ref. Silver Goop PWA36001 PMC9940	02570(m), A0019(s), A0037(s), A0038(s)
PWC06-032	Compound, Antigalling and Anti-seize (High Temperature) Ref. Fel-Pro C-200 US MIL-A-907 PWA586, PMC79912 (CPW37)	73165(m)

PRATT & WHITNEY CANADA
MAINTENANCE MANUAL
MANUAL PART NO. 3013242

TABLE 1, Consumable Materials (Cont'd)

Item	Nomenclature/Specification	Supplier Code
PWC06-033	Compound, Anti-seize (Paste) Ref. Dow 1000 US MIL-G-2761 Type 1	71984(m)
PWC07-002	Enamel, Glyceryl Phthalafe, Engine Gray Baking US AMS3125	A0001(s)
PWC07-008	Coating, Thermoal Insulating Ref. Flamarest BTX 1600 PMC79708, (CPW483)	63262
PWC07-012	Coating, Aluminum Heat and Corrosion Resistant Ref. SermeTel W PWA595-1, PMC9748 (CPW88)	58913(m), A0039(s), A0040(s)
PWC07-017	Coating, Surface Sealant (Corrosion Protection) Ref. Rockhard 576-450-002 (IP Araldite 961) PMC79964, CPW489	K3504(m), 00BB6(s), A0105(s)
PWC07-022	Coating, Touch-up Conversion Ref. TSD No. 1 (Air Drying Type)	A0001(s), A0065
PWC07-023	Coating, Aluminum and Zinc Ref. Serma Tel 249 PWA548 (CPW584)	58913(m), A0039(s), A0040(s)
PWC08-002	Adhesive Fluorosilicone Ref. DC RTV 730 PMC79924 (CPW317)	71984(m)
PWC08-009	Cement, Sealing, Thermocouple Ref. Sauereisen Filler No. 29 and Sauereisen Binder No. 29	80703, A0071

PRATT & WHITNEY CANADA
MAINTENANCE MANUAL
MANUAL PART NO. 3013242

TABLE 1, Consumable Materials (Cont'd)

Item	Nomenclature/Specification	Supplier Code
PWC08-010	Adhesive, Rubber Synthetic Ref. EC1357 (CPW324)	76381(m), A0083
PWC09-001	Sealant, Silicone Rubber Ref. DC RTV 732 (CPW519-11)	71984(m), K7750, D8367
PWC09-001A	Sealant, Silicone Rubber Ref. RTV 102, 103, 108, 109 (CPW519-11)	01139(B)(m)
PWC09-002	Compound, Locking and Retaining Anaerobic Ref. Loctite Grade 290 US. MIL-S-22473 PWA549-7, PMC79900 (CPW79-290)	05972(m), A0104(s), A0018, D2617, U0406
PWC09-002A	Compound, Locking and Retaining Anaerobic Ref. Loctite Grade 222 US. MIL-S-22473 PWA549-4, PMC79897	05972(m), A0104(s), A0018, D2617, U0406
PWC09-003	Compound, Sealing Silicone Ref. Dow Corning No. 4 US. MIL-S-8660 PMC9926, (CPW326)	71984(m), D8367
PWC09-005	Compound, Universal Jointing (Medium Grade) Ref. ST512 (CPW267-3)	K3237, 60543, S0116(m)
PWC09-006	Compound, Jointing Ref. ST512 (CPW267-4)	K3237, 60543, S0116
PWC11-001	Cleaner, Alkaline (Internal Engine Washing) Ref. CLIX	20913, 56444
PWC11-001A	Cleaner, Alkaline (Internal Engine Washing) Ref. Almon AL-333	A253
PWC11-001B	Cleaner, Alkaline (Internal Engine Washing) Ref. Magnus 1214	35502(m), 85884

PRATT & WHITNEY CANADA
MAINTENANCE MANUAL
MANUAL PART NO. 3013242

TABLE 1, Consumable Materials (Cont'd)

Item	Nomenclature/Specification	Supplier Code
PWC11-001C	Cleaner, Alkaline (Internal Engine Washing) Ref. B&B 3100 SPMC87-4	21361
PWC11-001D	Cleaner, Alkaline (Internal Engine Washing) Ref. R-MCS	N1480
PWC11-001E	Cleaner, Alkaline (Internal Engine Washing) Ref. R-MC G21	N1480, 58913
PWC11-001F	Cleaner, Alkaline (Internal Engine Washing) Ref. Turco 4217 Concentrate	36325(m), 0BYN5(m)
PWC11-001G	Cleaner, Alkaline (Internal Engine Washing) Ref. Turco T-5884 SPMC 87-12	36325(m),0BYN5(m)
PWC11-001H	Cleaner, Alkaline (Internal Engine Washing) Ref. Ardrex 624 Concentrate	A0052(s), 23373(s), 37127(s), K6858(m)
PWC11-001J	Cleaner, Alkaline (Internal Engine Washing) Ref. Triethanolamine	A0001(s)
PWC11-002	Was Solvent trichloroethane 1-1-1 Ref. NOTE	
NOTE: Use isopropyl alcohol (PWC11-014) to replace the trichloroethane solvent. You can also use SPOP 209, refer to the SPM, Chapter 70-21-00.		
PWC11-003	Cleaner, Detergent (Engine Washing) Ref. Ardrex 6345 SPMC87-2	K6858(m)
PWC11-003A	Cleaner, Detergent (Engine Washing) Ref. R-MC G21	N1480, 58913
PWC11-003B	Cleaner, Detergent (Engine Washing) (Biodegradable) Ref. Ardrex 6367 (TurboClean 2)	A0052(s), 23373(s), 37127(s), A0121(m), K6858(m)

PRATT & WHITNEY CANADA
MAINTENANCE MANUAL
MANUAL PART NO. 3013242

TABLE 1, Consumable Materials (Cont'd)

Item	Nomenclature/Specification	Supplier Code
PWC11-003C	Cleaner, Detergent (Engine Washing) (Biodegradable) Ref. Ardrex 6368 (Turboclean 2 RTU) (Ready to use)	A0052(s), 23373(s), 37127(s), K6858(m)
PWC11-003D	Cleaner, Detergent (Engine Washing) (Biodegradable) Ref. ZOK 27	A0042, S0081
PWC11-005	Cleaner, Solvent Ref. Envirosolv 655 PMC8914	05867
PWC11-008	Cleaner, Contact Ref. Caeon 27	55403(m)
PWC11-009	Alcohol, Ethyl US AMS3002 MIL-A-6091 O-E-760 TYPE III MIL-STD-1201 PMC9009	A0001(s)
PWC11-010	Alcohol, Methyl US AMS3004 O-M-232 Grade A PMC9089	A0001(s)
PWC11-012	Acetone Ref. Open PMC9008	A0001(s)
PWC11-013	No longer available. Use alternatives PWC11-013A, PWC11-049 or PWC11-061	
PWC11-013A	Compound, Carbon Removing Ref. HDP 2888 SPMC 12	02ER0(m)
PWC11-014	Alcohol, Isopropyl US Fed. TT-I-735 Grade A PMC9094	A0001(s)
PWC11-015	Flakes, Cupric Sulfate Technical Grade Ref. Open	A0001(s)

PRATT & WHITNEY CANADA
MAINTENANCE MANUAL
MANUAL PART NO. 3013242

TABLE 1, Consumable Materials (Cont'd)

Item	Nomenclature/Specification	Supplier Code
PWC11-020	Solvent, Carbon Removing Ref. Magnus 755	35502(m)
PWC11-021	Compound, Cold Carbon Removing Ref. Turco Super Carb PMC9047	0BYN5(m), 36325(m)
PWC11-021A	Compound, Cold Carbon Removing Ref. Penetone, Formula #423 PMC9031	56883
PWC11-021B	Compound, Cold Carbon Removing Ref. Wyandotte P-1075 PMC9084	88375
PWC11-022	Solvent, Cleaning Methyl Ethyl Ketone (MEK) US ASTM D740 PMC9076, (CPW79908) Ref. NOTE	A0001(s), 36842
NOTE: As an alternative, use the isopropyl alcohol (PWC11-014), acetone (PWC11-012), Ardrex Leeder 1064K (PWC11-023), Desoclean 45 (PWC11-025) or Envirosolv 655 (PWC11-005) to replace the MEK solvent. You can also use SPOP 209, refer to SPM, Chapter 70-21-00.		
PWC11-023	Solvent, Cleaning Ref. Ardrex Leeder 1064K PMC8904	A0052(s), 23373(s), 37127(s), K6858(m)
PWC11-024	Solvent, Methylene Chloride Ref. Open	A0001(s)
PWC11-025	Solvent, Cleaning Ref. Desoclean 45 PMC9060	0NYS9
PWC11-026	Was Solvent Trichlorethylene	
NOTE: As an alternative, use perchlorethylene PWC11-016 to replace trichlorethylene solvent.		
PWC11-027	Solvent, Petroleum US AMS 3160 US Fed. P-D-680 Type II NATO code S-753 PMC9001	A0001(s), 36131
PWC11-029	Solvent, Removing RTV Compound Ref. Chlorothene SM	A0001(s)

PRATT & WHITNEY CANADA
MAINTENANCE MANUAL
MANUAL PART NO. 3013242

TABLE 1, Consumable Materials (Cont'd)

Item	Nomenclature/Specification	Supplier Code
PWC11-031	Cleaner, Engine Ref. Tergit PMC79782	35502(m)
PWC11-032	Solvent, Degreaser Ref. Magkleen 4 PMC79789	35502(m)
PWC11-033	Cleaner, Aqueous Ref. Soliterj-304 PMC71254	35502(m)
PWC11-038	Solvent, Cleaning Ref. Deoxidine No. 624	71410, A0001(s)
PWC11-048	Solvent, Cleaning (Spray-on/Wipe-off) Ref. MAG-CHEM Teksol SPMC 156	02ER0(m)
PWC11-049	Remover, Rust, Alkaline Ref. Ardrox 185 SPMC52	A0052(s), 23373(s), 37127(s), A0121(m), 44389, 02CA7, D1940
PWC11-061	Remover, Rust, Alkaline Ref. MAG-CHEM HDL-202 (Liquid) SPMC 129	02ER0 (m)
PWC13-001	Primer, Epoxy Base: 519 x 303; + Curing Solution: 910-357; + Solvent 020 x 324 PWA568, PMC1721 PMC1722 (CPW268)	A0097(s), S0098(s), 0NYS9(m)
PWC15-001	Desiccant , Silica Gel (12 Unit Bags) US. MIL-D-3464 Grade 1 Activated	A0001(s)
NOTE: Desiccant is supplied in one unit bags. One unit weighs one ounce.		
PWC15-002	Indicator, Humidity Ref. MS20003-2 Humi-Spot	96043

PRATT & WHITNEY CANADA
MAINTENANCE MANUAL
MANUAL PART NO. 3013242

TABLE 1, Consumable Materials (Cont'd)

Item	Nomenclature/Specification	Supplier Code
PWC15-004	Compound, Corrosion Preventative (Hard Film, Hot Application) US AMS3075	A0001(s)
PWC15-013	Inhibitor, Corrosion (Type III, Class 1) Ref. Rustlick 631 DEF II	A0099
PWC15-013A	Inhibitor, Corrosion (Type III, Class 1) Ref. ZC-015	8E913
PWC15-013B	Inhibitor, Corrosion (Type III, Class 1) Ref. Alox 2028D	60773
PWC15-013C	Inhibitor, Corrosion (Type III, Class 1) Ref. Nox Rust 211	7X108
PWC15-013D	Inhibitor, Corrosion (Type III, Class 1) Ref. 2780	0W138
PWC15-013E	Inhibitor, Corrosion (Type III, Class 1) Ref. LPS-814-BULK	66724
PWC15-013F	Inhibitor, Corrosion (Type III, Class 1) Ref. Octoil 5069	82925
PWC15-013G	Inhibitor, Corrosion (Type III, Class 1) Ref. 2028CM-3 Bulk	33150
PWC15-013H	Inhibitor, Corrosion (Type III, Class 1) Ref. Technolube FE-008	A0100
PWC15-013J	Inhibitor, Corrosion (Type III, Class 1) Ref. Ardrex 3205	23373(m), A0101(s)
PWC15-013K	Inhibitor, Corrosion (Type III, Class 1) Ref. Batco Rust Preventative	60226

**PRATT & WHITNEY CANADA
MAINTENANCE MANUAL
MANUAL PART NO. 3013242**

TABLE 1, Consumable Materials (Cont'd)

Item	Nomenclature/Specification	Supplier Code
PWC15-013L	Inhibitor, Corrosion (Type III, Class 1) Ref. ACF-50	A0102

3. Suppliers and Supplier Services

The names of any companies provided in Table 2, as a possible source for required services or supplies, are furnished for information purposes only. Pratt & Whitney Canada Corp. does not endorse the work performed or supplies procured from these companies. Further, Pratt & Whitney Canada Corp. does not accept responsibility, to any degree, for the selection of such companies for such work performed or supplies procured.

The codes given are the Manufacturer's Commercial Agency of Government Entity (CAGE) number. A supplier used by Pratt & Whitney Canada (P&WC) and Pratt and Whitney America (PWA), who does not have a CAGE No., is given a SXXXX code by PWA. A supplier used only by P&WC, who does not have a CAGE No., is given an AXXXX code by P&WC.

TABLE 2, Supplier Codes and Addresses

Supplier Code	Name/Address
A0001(s)	Local Supply Local Purchase
A0002(s)	Butterfield (Litton) 91 Cornella St. West Smith Falls, Ontario Canada K7A 4T3 Tel.: (613) 283-8001 Fax: Telex: 05-33934
A0006	Dixon Ticonderoga Inc. 531 Davis Drive Newmarket, Ontario Canada L3Y 2P1 Tel.: (905) 263-4966 Fax: (905) 895-9555
A0013	Speedry Products Inc. Richmond Hill, NJ USA Tel.: Not available Fax: Not available

PRATT & WHITNEY CANADA
MAINTENANCE MANUAL
MANUAL PART NO. 3013242

TABLE 2, Supplier Codes and Addresses (Cont'd)

Supplier Code	Name/Address
A0015	Castrol Canada Inc. 2150 Rue Frances Hughes Chomedey, Ville de Laval, Quebec Canada H7S 1N7 Tel.: (450) 382-6940 Tel.: (900) 361-3837 Fax: Not available
A0018(s)	National Bearings Ltd. 724 Renaud Dorval, Quebec Canada H9X 1H5 Tel.: (514) 333-7000 Fax: Not available
A0019(s)	Vannes & Raccords Laurential Ltee. (A distributor of The Swagelok Co.) 2425 Halpern Ville St. Laurent, Quebec Canada H4S 1S3 Tel.: (450) 332-3651 Fax: (450) 332-4386
A0023(m)	Whitford Plastics Ltd. Brindley 86, Astmoor Runcom, Cheshire England SK10 4NJ Tel.: 01928-571000 Fax: 01928-571010
A0026	W.H. Brady Inc. 10 Marmac Drive Rexdale, Ontario Canada M9W 1E6 Tel.: (416) 675-7111 or (800) 387-3917 Fax: Not available
A0030(m)	Imperial Oil Canada 111 St. Clair Ave. W. Toronto, Ontario Canada M5W 1K3 Tel.: (416) 968-4111 Fax: (416) 968-4374
A0032	Antwerp Marine Center, S.A. Mechelsctteenweg 43 B-2000 Antwerp Belgium Tel.: 32-3-2320084 Fax: Not available

**PRATT & WHITNEY CANADA
MAINTENANCE MANUAL
MANUAL PART NO. 3013242**

TABLE 2, Supplier Codes and Addresses (Cont'd)

Supplier Code	Name/Address
A0033	L.L. LTD. 15 Russell Garden Mews London W14 8EU England Tel.: Not available Fax: Not available
A0034	Kian Seng Hardware Trading Pts. Ltd. 168 Sims Ave. Singapore Tel.: 14-3865-748-7144 Fax: Not available
A0035	F. Bacon & Co. Inc. Div. De Drummond-Sullivan Co. 274 Chemin Bates Mont Royal, Quebec Canada H3S 1A3 Tel.: (514) 737-3755 Fax: Not available
A0036	Ashburn Industries 3219 Harrisburg P.O. Box 2046 Houston, TX USA 77252 Tel.: Not available Fax: Not available
A0037(s)	Amsterdam Valve & Fitting G. Loewik BV (A distributor of The Swagelok Co.) P.O. Box 9050 1180 Amstelveen The Netherlands Tel.: (31) (20) 6470231 Fax: (31) (20) 6474267
A0038(s)	Singapore Valve & Fitting (Pte) Ltd. (A distributor of The Swagelok Co.) 28 Mandai Estate Singapore 729917 Tel.: (65) 3670688 Fax: (65) 3685300 Fax: Cable : SINVAF
A0039	Sermatech Canada Inc. 747 Riddle Avenue Dorval, Quebec Canada H9P 1H4 Tel.: (514) 631-2240 Fax: (514) 636-6196

PRATT & WHITNEY CANADA
MAINTENANCE MANUAL
MANUAL PART NO. 3013242

TABLE 2, Supplier Codes and Addresses (Cont'd)

Supplier Code	Name/Address
A0040	Sermatech United Kingdom Ltd. High Holborn Road Codnor Gate Industries Estate Ripley, Derbyshire United Kingdom DE5 3NW Tel.: (44) 1773-7489261 Fax: (44) 1773-512344
A0042	Airworthy Ltd. Elsted Midhurst, West Sussex England GU29 0JT Tel.: 730-816672 Fax: 730-815607
A0052	Trikon Technologies Inc. 6969 Trans-Canada Highway Suite 127 Saint-Laurent, Quebec Canada H4T 1V8 Tel.: (514) 339-5997 Fax: Not available
A0065	Turbine Support Division Chromally American Corp. 4430 Director Drive San Antonio, TX USA 78220 Tel.: (512) 333-6010 Fax: Not available
A0066	Semco Instruments Inc. 25700 Rye St. Valencia, CA USA 91355 Tel.: (805) 257-2000 Fax: (805) 295-0044
A0071	Corrosion Service Co. Ltd. 369 Rimrock Rd. Downsview, Ontario Canada M3J 3J2 Tel.: (416) 630-2600 Fax: (416) 630-2393

**PRATT & WHITNEY CANADA
MAINTENANCE MANUAL
MANUAL PART NO. 3013242**

TABLE 2, Supplier Codes and Addresses (Cont'd)

Supplier Code	Name/Address
A0083	3M Canada Inc. P.O. Box 5757 Oxford St. E. London, Ontario Canada N6A 4T1 Tel.: (519) 451-2500 Tel.: Telex: 064-5886 Fax: (519) 452-6262
A0084(s)	Millipore Canada Ltd. 36 Antares Drive, Suite 700 Nepean Ontario K2E 7W5 Canada Tel.: (800) 645 5476 Fax: (613) 225 9366
A0097(s)	Courtaulds Aerospace A Division of International Paints Canada Ltd. 5676 Timberlea Blvd. Mississauga, Ontario Canada L4W 4M6 Tel.: (905) 629-7999 Fax: (905) 629-7009
A0099	ITW Signode India Ltd. 5, SP Road Hyderabad-500016 India Tel.: Not available Fax: Not available
A0100	Technolube Products 5814 East 61st Street Los Angeles, CA USA 900400 Tel.: Not available Fax: Not available
A0101(s)	Brent Mexicana S.A. De C.V. Tiburcio Montiel 81 Col. San Miquel Chapultepec 11850-Mexico D.F. Mexico Tel.: Not available Fax: Not available

PRATT & WHITNEY CANADA
MAINTENANCE MANUAL
MANUAL PART NO. 3013242

TABLE 2, Supplier Codes and Addresses (Cont'd)

Supplier Code	Name/Address
A0102	Lear Chemical Research Corp. 1285 Britannia Road East Mississauga, Ontario Canada L4W 1C7 Tel.: Not available Fax: Not available
A0103(s)	Miller-Stephenson Chemical Co. Inc. 514 Carlingview Drive Rexdale, Ontario Canada M9W 5R3 Tel.: (416) 675-3204 or (800) 323-4621 Fax: (416) 674-2987 E-mail: www.miller-stephenson.com
A0104(s)	Loctite Canada Inc. 2225 Meadowpine Blvd. Mississauga, Ontario Canada L5N 7P2 Tel: (905) 814-6511 or (800) 263-5043 Fax: (905) 814-5391
A0105(s)	Matcon (A distributor of Indestructible Paints Ltd.) 10/2 Britto Complex 6th Cross, Victoria Layout Bangalore, India 560 047 Tel.: 9180-554-3805 Fax: 9180-544-3804
A0121(m)	Oakite Products of Canada, Ltd. 115 East Drive Bramalea, Ontario, L6T 1B7 Canada Tel.: (800) 526-4473 Tel.: (905) 791-1628 Fax: (905) 791-1527 Fax: (908) 464-7914 URL: www.oakite.com
A0123	Wahl Instruments Inc. 234 Weaverville Highway Asheville, NC 28804-1228 USA Tel.: (828) 658-3131 Tel.: (800) 421-2853 Fax: (828) 658-0728 E-mail: www.instrumentationgroup.com

PRATT & WHITNEY CANADA
MAINTENANCE MANUAL
MANUAL PART NO. 3013242

TABLE 2, Supplier Codes and Addresses (Cont'd)

Supplier Code	Name/Address
A253	Almon Quimico Wyandotte Corporation Rio-De-Janeiro Brazil Tel.: Not available Fax: Not available
D2617	Loctite Deutschland GmbH Arabellastrasse 17 Postfach 81 05 80 8000 Munchen 81 Germany Tel.: Not available Fax: Not available
D8367	Dow Corning GmbH Schmierstoffe Pelkovenstrasse 152 8000 Muenchen 50 Germany Tel.: Not available Fax: Not available
K1010	Raychem Limited Faraday Road Dorcan, Swindon United Kingdom SN3 5HH Tel.: 0793-528171 Fax: 0793-482297
K3237	Marston Bentley Ltd. 9 Naylor Street Liverpool, England L3 6DS Tel.: Not available Fax: Not available
K3504(m)	Indestructible Paint Co. Ltd. 25 Pentos drive Sparkhill, Birmingham United Kingdom B11 3TA Tel.: (0121) 702-2485 Fax: (0121) 778-4338

PRATT & WHITNEY CANADA
MAINTENANCE MANUAL
MANUAL PART NO. 3013242

TABLE 2, Supplier Codes and Addresses (Cont'd)

Supplier Code	Name/Address
K6858	Brent Europe Ltd. (Brent International PLC) Denbigh Road Bletchley, Milton Keynes Buckinghamshire England MK1 1PB Tel.: 44-1753-651812 Tel.: Telex: 847693 BRENT Fax: 44-1753-652460
K7750	Dow Corning Ltd. Molykote Division NG Co. Avco House Castle Street Reading Berks, RD1 7-Z United Kingdom Tel.: Not available Fax: Not available
N1480	Ivar Rivenaes A/S Damsgirds 35 N-5037 Solheimsvik Norway Tel.: 55-203390 Fax: 55-295925
S0036	Texrite Products Co. 10333 Shoemaker St. Detroit, MI USA 48213 Tel.: (313) 925-9002 Fax: (313) 925-9602
S0081	Lucas Avitron P.O. Box 120039 Stamford, CT 06912 USA Tel.: (203) 351-8400 Fax: (203) 351-8444
S0089	Avery Dennison Dennison Division One Clark Hill Farmington, MA USA 01701 Tel.: (508) 879-0511 Fax: (508) 383-4259
	or

**PRATT & WHITNEY CANADA
MAINTENANCE MANUAL
MANUAL PART NO. 3013242**

TABLE 2, Supplier Codes and Addresses (Cont'd)

Supplier Code	Name/Address
S0098(s)	Office Products Canada 200 Base Line Road East Bowmanville, Ontario Canada L1C 1A2 Tel.: (905) 623-6311 Fax: (905) 623-9751
S0116	ASC Philadelphia (A distributor of Courtaulds Aerospace) 823 East Gate Mt. Laurel, NJ USA 08054 Tel.: (609) 234-1600 Fax: (609) 234-5515
U0406	W. Canning Inc. 223 North Brockman St. Pasadena, TX USA 77506 Tel.: (713) 472-5081 or (800) 521-2589 Fax: (713) 472-2440
0BYN5	Loctite UK Ltd. Watchmead Welwyn Garden City Herts United Kingdom AL7 1-B Tel.: Not available Fax: Not available
0BZD7	Turco Products Inc. Sub. of Efl Atochem North America 7300 Bolsa Avenue Westminister, CA USA 92684-3600 Tel.: (714) 890-3600 Fax: (714) 892-7179
0CZB2	Liquid Air Engineering Corp. 1155 Sherbrooke St. W. Montreal, Quebec Canada H3A 1H8 Tel.: (514) 842-5431 Fax: Not available
0CZB2	Stoody Deloro Stellite Inc. Stellite Coatings Div. 1201 Eisenhower Dr. N. Goshen, ID USA 46526-5396 Tel.: (219) 534-2585 Fax: (219) 534-3417

**PRATT & WHITNEY CANADA
MAINTENANCE MANUAL
MANUAL PART NO. 3013242**

TABLE 2, Supplier Codes and Addresses (Cont'd)

Supplier Code	Name/Address
0HJT8	Airgas Northeast Inc. 325 McCausland Court Cheshire, CT USA 06410 Tel.: (203) 250-6800 Fax: (203) 250-6834
0NYS9(m)	PRC-Desoto International 5430 San Fernando Road Glendale, CA USA 91203 Tel.: (818) 240 2060 Fax: (818) 549-7595
0W138	Fine Organics Corp. 6935 West 62nd Street Chicago, IL USA 60638 Tel.: Not available Fax: Not available
00BB6(s)	Indestructible Paints Inc. 66 Erna Ave. Milford, CT USA 06460 Tel.: (203) 877-9243 Fax: (203) 876-7680
00198	Pratt & Whitney Canada Corp. Attn: Parts Support (Mail Code 01OE4) 1000 Marie Victorin Blvd. Longueuil, Quebec Canada J4G 1A1 Tel.: (450) 647-2777 Fax: (450) 647-2834
01058	Michigan Chrome & Chemical Co. 8615 Grinnel Ave. Detroit, MI USA 48213-1152 Tel.: (313) 267-5279 Fax: Not available
01139(A)	General Electric Co. Attn: Rubber and Fluid Products Dept. Attn: Customer Support 260 HudsonRiver Rd. Waterford, NY USA 12188 Tel.: (518) 233-3330 or (800) 255-8886 Fax: Not available

PRATT & WHITNEY CANADA
MAINTENANCE MANUAL
MANUAL PART NO. 3013242

TABLE 2, Supplier Codes and Addresses (Cont'd)

Supplier Code	Name/Address
01139(B) (m)	General Electric Co. Attn: Silicone Sales Dept. Attn: Customer Support 260 Hudson River Road Waterford, NY USA 12188 Tel.: (518) 233-3330 or (800) 255-8886 Fax: (518) 233-3931
02ER0(m)	MAG-CHEM 190 Blvd. Industriel Boucherville Quebec J4B 2X3 Canada Tel.: (800) 363 9929 Tel.: (450) 655 1344 Fax: (450) 655 5428 URL: www.magchem.com
02258	Enthone-OMI Inc. P.O. Box 1900 West Haven, CT USA 06516-4147 Tel.: (203) 934-8611 Fax: (203) 799-1513
02570(m)	Swagelok Co. (formally Crawford Fitting Co.) 29500 Solon Road Solon, OH USA 44139 Tel.: (440) 248-4600 Fax: (440) 349-5970
03042	Dennison Carter (Ref. S0089)
03530	American Gas & Chemicals Co. Ltd. 220 Pegasus Ave. Northvale, NJ USA 07647-1904 Tel.: (201) 767-7300 or (800) 288-3647 Fax: 9201) 767-1741 E-mail: agc@amgas.com
05838	Philips Elmet Corp. 1560 Lisbon Road Lewiston, ME USA 04240 Tel.: (207) 784-3591 or (800) 526-7480 Fax: Not available

PRATT & WHITNEY CANADA
MAINTENANCE MANUAL
MANUAL PART NO. 3013242

TABLE 2, Supplier Codes and Addresses (Cont'd)

Supplier Code	Name/Address
05867	Fine Organics Corp. 205 Main Street P.O. Box 687 Lodi, NJ USA 07644-0687 Tel.: (973) 472-6800 or (800) 526-7480 Fax: (973) 472-6810 E-mail: chembiz@aol.com
05972(m)	Permatex Industrial Corp. Div. of Loctite North America Group 1001 Trout Brook Crossing Rock Hill, CT USA 06067-3910 Tel.: (860) 571-5100 Fax: (860) 571-5465
06090	Raychem Corp. Electronic Systems Group 300 Constitution Drive Menlo Park, CA USA 94025-1111 Tel.: (650) 361-3333 Fax: (650) 361-3485
08071(m)	Millipore Corporation 80 Ashby Road Bedford MA 01730-2271 USA Tel.: (781) 275 9200 Fax: (781) 275 5550
08338	Allied Chemicals Canada Ltd. Fluorine Products 201 City Centre Dr. Mississauga, Ontario Canada L5B 2T4 Tel.: (905) 276-9211 Fax: (905) 276-5711
09185(m)	Litton Industries. Kester Solder Division 515 E. Touhy Ave. Des Plaines, IL USA 60018-2675 Tel.: (847) 297-1600 or (800) 253-7837 Fax: (847) 390-9338 or (847) 699-5548 E-mail: customerservice@kester.com Web: www.kester.com

**PRATT & WHITNEY CANADA
MAINTENANCE MANUAL
MANUAL PART NO. 3013242**

TABLE 2, Supplier Codes and Addresses (Cont'd)

Supplier Code	Name/Address
1A053(s)	AAA Aircraft Supply Co. 36 Suffield Street P.O. Box 411 Windsor Locks, CT 06096-1320 USA Tel.: (860) 627-0181 Fax: (860) 623-2483
1C394	Dulson Frank and Co. Ltd. 5760 Pare Street Montreal, Quebec Canada H4P 1R9 Tel.: (514) 735-4681 Fax: (514) 735-8566
1DD67(m)	Miller-Stephenson Chemical Co. Inc. 6348 Oakton Street Morton Grove, IL USA 60053 Tel.: (847) 966-2022 or (800) 992-2424 Fax: (847) 966-8468 E-mail: www.miller-stephenson.com
1E473(m)	Miller-Stephenson Chemical Co. Inc. 12261 Foothill Boulevard Sylamar, CA USA 91342 Tel.: (818) 896-4714 or (800) 992-2424 Fax: (818) 896-6086
1V074	Sulflo Inc. 1158 Erie Ave. P.O. Box 285 North Tonawanda NY USA 14120-3507 Tel.: (716) 695-3585 Fax: (716) 695-0367
10178(s)	Kester Solder Co. of Canada Ltd. 1 Prince Charles Road P.O. Box 474 Brantford, Ontario Canada N3T 5N9 Tel.: (519) 753-3425 Fax: (519) 753-0641 Web: www.kester.com

PRATT & WHITNEY CANADA
MAINTENANCE MANUAL
MANUAL PART NO. 3013242

TABLE 2, Supplier Codes and Addresses (Cont'd)

Supplier Code	Name/Address
18598(m)	Miller-Stephenson Chemical Co. Inc. George Washington Highway P.O. Box 905 Danbury, CT USA 06813 Tel.: (203) 743-4447 or (800) 992-2424 Fax: (203) 791-8702 E-mail: www.miller-stephenson.com
2R128	Castrol Inc. Speciality Products Division Suite 230 16715 Van Karman Avenue Irvine, CA USA 92714 Tel.: (714) 660-9414 or (800) 458-5823, Ext. 3012 Fax: Not available
2R602	Astrolite Alloys Div. of Astro Metallurgical 709 Via Alondra Camarillo, CA USA 93010-8714 Tel.: (805) 484-3621 or (800) 235-5935 Fax: (805) 388-0577
20913	NCH Corp. P.O. Box 152170 2727 Chemsearch Blvd. Irving, TX USA 75015 Tel.: (214) 438-0211 Fax: Not available
21361	B & B Trittech Inc. 875 West 20th St. Hialeah, FL USA 33010-2310 Tel.: (305) 888-5247 Fax: (305) 887-4587
22980 (m)	Sanford (A Newell Co.) 2711 Washington Blvd. Bellwood, IL USA 60104 Tel.: (708) 649-3513 Fax: (708) 649-3594 E-mail: www.sanfordcorp.com

**PRATT & WHITNEY CANADA
MAINTENANCE MANUAL
MANUAL PART NO. 3013242**

TABLE 2, Supplier Codes and Addresses (Cont'd)

Supplier Code	Name/Address
23373(m)	<p>Brent America Inc. 16961 Knott Avenue La Mirada, CA USA 90638-6015 Tel.: (714) 739-2821 Fax: (714) 670-6480 or</p> <p>Brent America Inc. 921 Sherwood Dr. Lake Bluff, IL USA 90044 Tel.: (847) 295-1660 Fax: (847) 295-8748</p>
25645	<p>Whitford Corp. 33 Sproul Road Frazer, PA USA 19355 Tel.: (610) 296-3200 Fax: (610) 647-4849</p>
28112	<p>Minnesota Mining & Mfg. Co. 3M Company Industrial Chemical Products 3M Center St. St. Paul, MN USA 55144-1000 Tel.: (800) 364-3577 Fax: (612) 737-7117</p>
28835	<p>Hobart Bros. Co. Hobart Square 600 W. Main Street Troy, OH USA 45373 Tel.: (937) 332-4000 Fax: (937) 332-4090</p>
29372	<p>Fairchild Industries Inc. Fairchild Aerospace Fastener Division 3000 West Lomita Blvd. Torrance, CA USA 90505-5103 Tel.: (310) 784-0700 or (310) 530-0963 Fax: (310) 539-6940</p>

PRATT & WHITNEY CANADA
MAINTENANCE MANUAL
MANUAL PART NO. 3013242

TABLE 2, Supplier Codes and Addresses (Cont'd)

Supplier Code	Name/Address
30133	Ideal Stencil Machine and Tape 102 Iowa Avenue P.O. Box 305 Belleville, IL USA 62222-0305 Tel.: (618) 233-0162 Fax: Not available
33150	Steven Industries, Inc. 39 Avenue C Bayonne, NJ USA 07002 Tel.: Not available Fax: Not available
33333	Washington Mills Electro Minerals Corp. 1801 Buffalo Avenue Niagara Falls NY USA 14302 Tel.: (716) 278-6600 or (800) 828-1666 Fax: Not available
33564(A)	Dexter Aerospace Materials Division 2850 Willow Pass Rd. Pittsburg, PA USA 94565-3299 Tel.: (510) 458-8000 Fax: (510) 458-8030
33564(B)	Dexter Aerospace Electronic Materials Division 211 Franklin Street Orlean, NY USA 14760 Tel.: (716) 372-6300 Fax: (716) 372-6864
35502	Magna Chemical Ltd. 190 Blvd. Industriel Boucherville, Quebec Canada J4B 2X3 Tel: (450) 655-1344 Fax: (450) 655-5428

**PRATT & WHITNEY CANADA
MAINTENANCE MANUAL
MANUAL PART NO. 3013242**

TABLE 2, Supplier Codes and Addresses (Cont'd)

Supplier Code	Name/Address
36131	Shell Canada Products Limited 400 4th Ave. SW P.O. Box 100 Station M Calgary, Alberta Canada T2P 2H5 Tel.: (403) 691-3111 Fax: (403) 691-3777
36325	Deane & Co. Div. of Groulx-Robertson Ltee./Ltd. 190 Oneida Drive Pointe Claire, Quebec Canada H9R 1A8 Tel.: (514) 697-3730 Fax: (514) 697-3887
36382	Witco Canada 565 Coronation Drive West Hill, Ontario Canada M1E 2K3 Tel.: (416)284-1661 Fax: (416) 284-4316
36842	Anachemia Canada Inc. 500 2nd Avenue Ville St. Pierre, Quebec Canada H8R 1M3 Tel.: (514) 489-5711 Fax: (514) 363-5281
37127(m)	Brent Canada Ltd. 363 Arvin Avenue Stoney Creek, Ontario Canada L8E 2M8 Tel.: (905) 662-8046 Fax: (905) 662-5966
39211	Interfast Inc. 21 Constellation Court P.O. Box 6984 Toronto, Ontario Canada M9W 1K4 Tel.: (416) 674-0770 Fax: (416) 674-5804

PRATT & WHITNEY CANADA
MAINTENANCE MANUAL
MANUAL PART NO. 3013242

TABLE 2, Supplier Codes and Addresses (Cont'd)

Supplier Code	Name/Address
39918	Sulzer Metco (Westbury) Inc. 1101 Prospect Ave. Westbury, Long Island, NY USA 11590-2724 Tel.: (516) 334-1300 Fax: (516) 338-2486
44197 (m)	Norton Co. (Export Sales) 1 New Bond Street P.O. Box 15008 Worcester, MA USA 01606-0008 Tel.: (508) 795-5307 or (800) 446-1119 Fax: (508) 795-4130
44389	Oakite Products Inc. (Chemetall Chemical Products Inc.) 50 Valley Road Berkeley Heights, NJ 07922-2712 USA Tel.: (800) 526-4473 Tel.: (908) 508-2214 Fax: (908) 464-7914 URL: www.oakite.com
5W425(m)	Emhart Corp. Bostik Division Boston Street Middleton, MA USA 01949 Tel.: (978) 777-0100 Fax: (978) 750-7212
55403(m)	Caig Laboratories Inc. 12200 Thatcher Court Poway, CA USA 92064 Tel.: (858) 486-8388 Fax: (858) 486-8398 E-mail: caig123@caig.com Website: http://www.caig.com
56444	National Chemsearch 245 Orenda Road Bramalea, Ontario Canada L6T 1E7 Tel.: (416) 457-5220 or (800) 268-0804 Fax: (416) 457-5220

PRATT & WHITNEY CANADA
MAINTENANCE MANUAL
MANUAL PART NO. 3013242

TABLE 2, Supplier Codes and Addresses (Cont'd)

Supplier Code	Name/Address
55596	Polymet Corp. 10073 Commerce Park Drive Cincinnati, OH USA 45246 Tel.: (513) 874-3586 Fax: (513) 874-2880
56883	Penetone Corp. Sub. of West Chemical Products Inc. 74 Hudson Avenue Tenafly, NJ USA 07670-1017 Tel.: (201) 567-3000 Fax: (201) 569-5340
57965	Stoody Deloro Stellite Welding Rods & Wires Division 16425 Gale Avenue Industry, CA USA 91749 Tel.: (818) 968-0717 or (800) 227-9333 Fax: Not available
58401(m)	United States Welding Corp. 3579 Hwy., 50 East #104 Carson City, NV USA 89701 Tel.: (702) 883-7878 or (800) 423-5964 Fax: (702) 883-7776 E-mail: www.usweldingcorp.com
58913 (m)	Sermatech International Inc. Materials Division 155 South Limerick Road Limerick, PA USA 19468-1603 Tel.: (610) 948-5100 Fax: (610) 948-5407
58933	Furon CHR Division T & F Furon Division 3660 Edison Place Rolling Meadows, IL USA 60008-1013 Tel.: (708) 392-8090 or (800) 323-1650 Fax: (708) 392-0403

PRATT & WHITNEY CANADA
MAINTENANCE MANUAL
MANUAL PART NO. 3013242

TABLE 2, Supplier Codes and Addresses (Cont'd)

Supplier Code	Name/Address
59595	Texaco Inc. 2000 Westchester Avenue White Plains, NY USA 10650 Tel.: (914) 253-4000 Fax: (914) 253-7753 or Reverside Drive East Hartford, CT USA 06118 Tel.: (860) 569-8297 Fax: Not available
60226	Battenfield Grease & Oil Corp. of New York 1174 Erie Avenue P.O. Box 728 North Tonawanda, NY USA 14120 Tel.: (716) 695-2100 Fax: Not available
60543	Ryder-Aviall 2075 Diplomat P.O. Box 7086 Dallas, TX USA 75234 Tel.: (214) 406-2000 Fax: Not available
60773	Alox Corporation 3943 Buffalo Ave. P.O. Box 517 Niagara Falls, NY USA 14302 Tel.: Not available Fax: Not available
61158(m)	Unifrax Corp. (The Carborundum Co.) 2351 Whirlpool St. Niagara Falls, NY USA 14305-2413 Tel.: (716) 278-3827 Tel.: Canada: (800) 635-4464 Fax: (716) 278-3904 E-mail: www.unifrax.com

PRATT & WHITNEY CANADA
MAINTENANCE MANUAL
MANUAL PART NO. 3013242

TABLE 2, Supplier Codes and Addresses (Cont'd)

Supplier Code	Name/Address
63262	Textron Speciality Materials Sub. of Textron Inc. 2 Industrial Avenue Lowell, MA USA 01851-5107 Tel.: (978) 452-8961 Fax: (978) 454-5619
63726	Metallurgical Technologies Inc. 14436 Max Road Route 4, Box 4752 Pearland, TX USA 77581-9709 Tel.: (281) 485-7765 Fax: (281) 485-0211
66724 (m)	LPS Laboratories Division of Holt Lloyd Corp. P.O. Box 105052 4647 Hugh Howell Road Tucker, GA USA 30084-5052 Tel.: (800) 241-8334 Fax: (770) 493-9206 E-mail: lpslabs@ix.netcom.com
7X108	Daubert Chemical Co. Inc. 4700 South central SW Chicago, IL USA 60638 Tel.: (312) 496-7350 Fax: Not available
70362	Dixon Ticonderoga Co. Sandusky Division 1706 Hayes Avenue P.O. Box 2258 Sandusky, OH USA 44870-4732 Tel.: (419) 625-9545 or (800) 824-9430 Fax: (419) 625-0719
71410	Parker & Amchem Division of Henkel Corp. 32100 Stephenson Hwy. Madison Heights, MI USA 48071 Tel.: (800) 222-2600 Ext. 286 Tel.: (800) 583-9300 Ext. 261 Fax: (248) 583-9387

PRATT & WHITNEY CANADA
MAINTENANCE MANUAL
MANUAL PART NO. 3013242

TABLE 2, Supplier Codes and Addresses (Cont'd)

Supplier Code	Name/Address
71984(m)	Dow Corning Corp. 2200 West Salzburg Rd. P.O. Box 994 Midland, MI USA 48686-0994 Tel.: (517) 496-6000 or (800) 248-2481 Fax: (517) 496-6974
73165	Fel-Pro Inc. Div. of Felt Products Mfg. Co. 7450 North McCormick Blvd. P.O. Box 1103 Skokie, IL USA 60076-8103 Tel.: (847) 674-7700 or (800) 323-4356 Fax: (847) 674-0019
73219	Fiske Brothers Refining Co. 129 Lockwood Street Newark, NJ USA 07105-4720 Tel.: (973) 589-9150 Fax: (973) 589-4432
75437	EOE Inc. 585 Fourth Street P.O. Box 177 Troy, Ny USA 12181 Tel.: (518) 272-6922 Fax: (518) 272-2182
75554	Jackson Lea A unit of Jackson Inc. 75 Progress Lane P.O. Box 71 Waterbury, CT USA 06705 Tel.: (203) 753-5118 Fax: (203) 754-3770
76071	Macdermid Inc. 245 Freight Street Waterbury, CT USA 06702 Tel.: (203) 575-5700 or (800) 325-4158 Fax: Domestic: (203) 575-5630 Fax: International: (203) 575-7900

**PRATT & WHITNEY CANADA
MAINTENANCE MANUAL
MANUAL PART NO. 3013242**

TABLE 2, Supplier Codes and Addresses (Cont'd)

Supplier Code	Name/Address
76381(m)	3M Company 3M Center St. Paul, MN USA 55144-1000 Tel.: (612) 737-6501 or (800) 364-3577 Fax: (612) 737-7117
8E913	Zip-chem Products A division of ANDPAK-EMA, Inc. 1860 Dobbin Drive San Jose, CA USA 95133 Tel.: (408) 729-0291 Fax: (408) 272-8062
8R378	Hammill and Gillespie Inc. 154 Livingstone Avenue P.O. Box 104 Livingstone, NJ USA 07039-3017 Tel.: (201) 994-3650 Fax: Not available
8W577(m)	Aerospace Specifications Metals 1384 W. McNab Rd. Ft. lauderdale, FL USA 33309 Tel.: (954) 977-0666 Fax: (954) 977-3858
80703	Saureisen Cements Co. 160 Gamma Drive Pittsburgh, PA USA 15238-2920 Tel.: (412) 963-0303 Fax: (412) 963-7620
82682(m)	Tempil Inc. 2901 Hamilton Road South Plainfield, NJ USA 07080 Tel.: (800) 757-8300 Fax: (908) 757-9273
82925	Octagon Processes, Inc. 596 River Road Edgewater, NJ USA 07020 Tel.: (201) 945-9400 Fax: Not available

PRATT & WHITNEY CANADA
MAINTENANCE MANUAL
MANUAL PART NO. 3013242

TABLE 2, Supplier Codes and Addresses (Cont'd)

Supplier Code	Name/Address
85665	Witco Corp. 1 American Lane Greenwich, Conn. USA 06831-2559 Tel.: 1-800-494-8287 Fax: (203) 552-2849 Intl. Fax: (203) 552-3414
85884	Ecolab Inc. Ecolab Center 370 Wabasha St. St. Paul, MN USA 55102-1307 Tel.: (612) 293-2570 Fax: Not available
86459(m)	Penreco 138 Petrolia St. Karns City, PA USA 16041 Tel.: (800) 245-3952 Fax: (724) 756-1050
87889	The Texacone Co. 4111 Forney Rd. Mesquite, TX USA 75149-2722 Tel.: (800) 235-2727 Fax: Not available
88375	Wyandotte Paint Products Co. 650 Stephenson Highway P.O. Box 1196 Troy, MI USA 48099 Tel.: Not available Fax: Not available
9X212	Shell International Petroleum Co. Shell Center London, SE1 7NA England Tel.: 44-171-934-1234 Fax: 44-171-934-8060

PRATT & WHITNEY CANADA
MAINTENANCE MANUAL
MANUAL PART NO. 3013242

TABLE 2, Supplier Codes and Addresses (Cont'd)

Supplier Code	Name/Address
96043	Driaire 26 Fitch St. P.O. Box 569 South Norwalk, CT USA 06856 Tel.: Not available Fax: Not available
98148(m)	Dykem Co. 3624 West Lake Ave. Glenview, IL USA 60025 Tel.: (800) 323-9538 Fax: (800) 323-9536
99742	Permacel Div. of Nitto Penko America U.S. Highway No. 1 P.O. Box 671 New Brunswick, NJ USA 08903 Tel.: (732) 418-2400 Tel.: Telex: 6858014 PERMACEL Fax: (732) 418-2739

